



U.S. Department  
of Transportation

**National Highway  
Traffic Safety  
Administration**

1200 New Jersey Avenue, SE  
Washington, DC 20590

OCT 14 2011

David D. Dillon, Sr. Manager  
Product Investigations and Campaigns  
Chrysler Group LLC  
800 Chrysler Drive, CIMS 482-00-91  
Auburn Hills, MI 48326

Re: Request for modification of confidential treatment (PE10-031)

Dear Mr. Dillon:

On September 30, 2011, we received a submission from Paul V. Sheridan requesting that NHTSA modify an existing grant of confidential treatment for engineering drawings submitted by Chrysler Group LLC (Chrysler) in the above referenced investigation. Chrysler submitted this information on October 15, 2010 accompanied by a request for confidential treatment. That request for confidential treatment was granted on March 31, 2011.

NHTSA's October 15, 2010 letter granted your request for confidential treatment on the basis that the engineering drawings in the submission are subject to the class determination for blueprints and engineering drawings found in Appendix B of 49 C.F.R. § 512. As you are aware, Appendix B creates a presumption that release of certain classes of information, including engineering drawings, would be likely to cause a submitter to suffer substantial competitive harm.

Section 512.22 of Part 512 establishes authority for NHTSA's Chief Counsel to modify a prior grant of confidential treatment under certain conditions, including, but not limited to, the passage of time or a finding that a confidentiality determination was erroneous. We are construing Mr. Sheridan's submission as a request that the Chief Counsel consider modification of the March 31, 2011 determination under § 512.22.

Before taking further action in response to Mr. Sheridan's request, we ask that Chrysler state its position regarding the potential release of these drawings. A copy of Mr. Sheridan's submission is enclosed for your review. We request that you respond by October 31, 2011.

After October 24, 2011, intend to make a determination on how to respond to Mr. Sheridan's request. If the Chief Counsel believes that an earlier determination of confidentiality should be modified, you will be notified in writing and provided with an opportunity to respond in not less than twenty working days from the date of receipt of notice of modification.  
49 C.F.R. § 512.22(b).

Sincerely,



Otto G. Matheke, III  
Senior Attorney

Enclosure

cc: Paul V. Sheridan



FedEx Express  
Customer Support Trace  
3875 Airways Boulevard  
Module H, 4th Floor  
Memphis, TN 38116

U.S. Mail: PO Box 727  
Memphis, TN 38194-4643

Telephone: 901-369-3600

October 2, 2011

Dear Customer:

The following is the proof-of-delivery for tracking number **869667283746**.

---

**Delivery Information:**

<b>Status:</b>	Delivered	<b>Delivered to:</b>	Receptionist/Front Desk
<b>Signed for by:</b>	T.MAPP	<b>Delivery location:</b>	1200 N.J. AVE SE W41 306 20590
<b>Service type:</b>	Express Saver Pak	<b>Delivery date:</b>	Sep 29, 2011 13:11

---

**Shipping Information:**

<b>Tracking number:</b>	869667283746	<b>Ship date:</b>	Sep 27, 2011
		<b>Weight:</b>	3.0 lbs/1.4 kg

**Recipient:**  
MR DAVID STRICKLAND  
NHTSA-WEST BLDG  
1200 NEW JERSEY AVE S E  
20590 US

**Shipper:**  
PAUL SHERIDAN  
SHERIDAN, PAUL V  
22357 COLUMBIA ST  
481243431 US

**Reference**

PE-10031

Thank you for choosing FedEx Express.

FedEx Worldwide Customer Service  
1.800.GoFedEx 1.800.463.3339

To: Mr. David L. Strickland \*  
NHTSA Headquarters/West Building  
1200 New Jersey Avenue, SE  
Washington, DC 20590  
888-327-4236

Date: 27 September 2011

VIA FEDEX AIRBILL #8696-6728-3746

From: Mr. Paul V. Sheridan  
DDM Consultants  
22357 Columbia Street  
Dearborn, MI 48124-3431  
313-277-5095  
[pvs6@Cornell.edu](mailto:pvs6@Cornell.edu)

**Reference : NHTSA Action Number PE10031  
(Jeep Grand Cherokee Fuel System Crashworthiness Defect Investigation)**

**Subject : Chrysler Group, LLC Request for Confidential Treatment of Public Information**

### Courtesy Copy List

Mr. Clarence Ditlow, Director \*\*  
Center for Auto Safety  
Suite 330  
1825 Connecticut Ave, NW  
Washington, DC 20009-5708  
(202) 328-7700

Mr. Courtney E. Morgan, Jr. \*\*  
Morgan & Meyers, PLLC / Suite 320  
3200 Greenfield Road  
Dearborn, MI 48120  
313-961-0130

Ms. Angel M. DeFilippo \*\*  
Grieco Oates & DeFilippo, LLC  
414 Eagle Rock Avenue  
West Orange, NJ 07052  
973-243-2099

\* Available here: <http://links.veronicachapman.com/Sheridan2Strickland-2.pdf>

\*\* Via Email

DDM Consultants  
22357 Columbia Street  
Dearborn, MI 48124-3431  
313-277-5095

27 September 2011

[VIA FEDEX AIRBILL #8696-6728-3746](#)

Mr. David L. Strickland, Administrator  
NHTSA Headquarters  
1200 New Jersey Avenue, SE  
Washington, DC 20590  
888-327-4236

**Reference : NHTSA Action Number PE10031  
(Jeep Grand Cherokee Fuel System Crashworthiness Defect Investigation)**

**Subject : Chrysler Group, LLC Request for Confidential Treatment of Public Information**

Dear Mr. Strickland:

The Chrysler Group has requested the sealing of materials submitted to NHTSA in response to PE10031. This request was made by Mr. David D. Dillon on 15 October 2010 (Attachment 1). Mr. Dillon, who is deployed by the Chrysler Group as a defense witness in product litigation involving fire deaths and/or injuries in the 1993 thru 2004 Jeep Grand Cherokee, stated in-part:

*“The business information for which confidential treatment is sought is 20 engineering drawings . . . This submission is subject to the substantial competitive harm standard set forth in 49 C.F.R. § 512.15(b) . . . The engineering drawings contain the detailed design specifics for various components of two vehicles. Competitors could use this design information to improve their own designs without incurring the time and expense associated with independent design efforts. As a result, Chrysler Group’s competitors could bring to market their products much quicker and at less cost.”*

The purpose of this instant submission is to present why Dillon’s demand, in this instance involving information that has been in the public domain for 25 years, is disingenuous. Although there are additional topics that support this status, I will restrict this presentation to six main topics:

1. Reverse Engineering and Anti-Reverse Engineering
2. Automotive Companies Practice of ‘Competitive Teardown’
3. Competitive Information Office
4. Inter-Automotive Company Defections
5. Chrysler Group relationships with OEM Outside Suppliers (PS-7000)
6. Chrysler Group (MOPAR) relationships with Replacement/Aftermarket Suppliers

### **Reverse Engineering and Anti-Reverse Engineering**

In far too many forums Chrysler Group defense lawyers (in particular) and internal government relations staff have declared that *“reverse engineering is impossible.”* You should presume that such declarations are meant to insult our integrity and intelligence; other than outright inaccuracy, there is no other explanation for such preposterous outbursts.

Accredited four/five-year engineering degree programs (which fulfill Chrysler Group Personnel Office minimums for existing or potential Engineering Department staff) require core coursework in reverse engineering. An entry level engineer is expected to be familiar with and capable of this standardized, routinely taught skill. This is well-known.

Reverse engineering is not a matter of cheating or stealing. It is common that an organization will be forced to reverse engineer a component or system because, through the passage of time, documentation has been lost or mistakenly destroyed.

But the more strident examples of reverse engineering involve military hardware, and its implications for national defense. Reverse engineering is deployed to acquire detailed and exact information about devices and equipment that were created by a strategic opponent. In this context, Chrysler Group LLC is in a special position as an automotive company given its history of transferring Chrysler Defense Group and Chrysler Electronics Group engineers into their automotive engineering departments. I interacted with engineering and product development staff who exemplified this personnel history. In the opposite scenario, Chrysler defense lawyers would do well to educate themselves on the basic history of the Tupolev TU-4; a creation of the Soviet Union that was the result of the infamous reverse engineering of America's Boeing B-29 Superfortress.<sup>1</sup>

But we must stress an esoteric issue. In the area of strategic defense, high-end military suppliers are contractually obligated to include protection by use of anti-reverse engineering designs. If an opponent acquired U.S. military equipment, that opponent would be thwarted, at least for a time, from determining *“design information to improve their own designs without incurring the time and expense associated with independent design efforts.”*<sup>2</sup>

By way of comparison and example, at no time did Mr. Francois Castaing, then Executive Vice President of Chrysler Engineering and Jeep Product Executive, direct that any aspect of any Chrysler product include anti-reverse engineering protections. Also, at no time was a requirement for anti-reverse engineering demanded of our suppliers, which provided up to 55% of Chrysler product content.

As will be detailed below, the moment a competitor acquires a Chrysler product, that product undergoes reverse engineering; a practice that is anything but impossible. The ability to reverse engineer a design that has been protected is difficult, but even that is far from impossible. But the 1993 ZJ-Body Jeep Grand Cherokee, that was designed over twenty years, can easily be reverse engineered. I can assure you our competitors did so immediately upon acquiring the ZJ-Body at market introduction in 1992

It is well-known to Chrysler government relations staff such as Mr. Dillon that reverse engineering in the automotive industry is routine, but that anti-reverse engineering protection is non-existent.

**Automotive Industry Practice of 'Competitive Teardown'**

As is well-known to Chrysler Group defense lawyers, I have testified about 'Competitive Teardown.' Excerpted below is a portion of my many prior expert reports in behalf of plaintiffs:

*"Throughout my career at Chrysler, my duties pertaining to competitive automobiles included detailed review of competitive engineering of components and systems. Routinely competitive vehicles were fully dismantled by Chrysler technicians from the Competitive Teardown Office. This "teardown" function was/is an integral part of the engineering and product development process. Its purpose was/is to accumulate detailed engineering information of competitive component and system design. The teardown process resulted in the following report and review formats:*

- a. *The Competitive Teardown Review: These formal reviews were presented by the engineering staffs, and frequently attended by the highest levels of Chrysler executive management.*
- b. *Competitive Teardown Report: Documentation which was distributed throughout the Chrysler organization, including the highest levels of Chrysler executive management. These reports included detailed information about competitive components and subsystem content, cost, weight, supplier sources, etc.*
- c. *Reviews by individual engineering or product planning personnel as part of their day-to-day responsibilities. Typically the teardown components were displayed on vertically hung 4 x 8 sheets of plywood, for analysis and inspection by the individual engineering or product planning groups. This display area was affectionately referred to as "The Boards."*
- d. *Competitive Teardown Office visits: Involve open, non-formal inspection on an as-needed basis.*

*As part of my duties at Chrysler I routinely provided managerial input on the selection of which competitive vehicles would be budgeted for teardown. To the best of my knowledge, the practice of Competitive Teardown Review continues at Chrysler to this day."*

During the last two decades no rebuttal to my above trial testimony has been offered into evidence by Chrysler defense lawyers. At no time during my 31-year involvement with the automotive industry has anyone decided that competitive teardown be suspended because *"reverse engineering is impossible."* It was never suggested that the internal funds allocated for Competitive Teardown be axed because it was not valuable, and that the budgetary savings be redirected to other engineering activities. As a former Engineering Programs Manager for Chrysler, I certainly never made any such suggestion.

From 1992 until my *ex parte* dismissal in 1994 I was Chairman of the Chrysler Minivan Safety Leadership Team (SLT). A member of the SLT was Mr. Fred Schmidt of Engineering Programs Management. Part of Mr. Schmidt's role included reports on the selection and scheduling of competitive teardowns. In this context, SLT review of "The Boards" was focused on acquisition of detailed information on competitive safety components and systems. One prominent example in this era was SLT review of competitive minivan liftgate latches that were compliant with FMVSS-206 (Attachment 2).<sup>3</sup>

### **Competitive Information Office**

A standard practice within and among automotive companies is the open solicitation of competitive information directly from competitors. A part of Sales & Marketing, the Chrysler group responsible for this activity was the 'Competitive Information Office' (Attachment 3).

A two-year member of the Chrysler Minivan Safety Leadership Team (SLT) was Mr. Michael Delahanty. He would update the SLT regarding details of existing and anticipated competitive activity. Mr. Delahanty focused on competitive safety components and systems, and also upcoming competitive sales, marketing and advertising claims regarding safety.

Institutionalized inside the industry, Competitive Information Office activity is also known-to and endorsed by defense lawyers, as well as the highest levels of automotive executive management.

### **Inter-Automotive Company Defections**

On June 14, 2011 I attended the deposition of Mr. Francois Castaing, former Executive Vice President of Chrysler Engineering and Jeep Product Executive. He was deposed in the Jeep Grand Cherokee fire-related death case of Kline vs. Lomans Auto Group, et al.<sup>4</sup> In preparation I provided a work file entitled 'Defections.' This file documents a plethora of employment defections between direct competitors at all levels of automotive engineers and executive management.

My file includes pronouncements regarding my former boss, Mr. Robert Lutz.<sup>5</sup> The 3 August 2001 front page Detroit News article, "*LUTZ RIDES IN TO REV UP GM: DCX LOSES VALUED ADVISOR*" explained with gala that Lutz would deploy the detailed information that he acquired during his twelve years at a direct competitor: Chrysler Corporation. But Mr. Lutz is just one example. To emphasize the relevant point made below, a small sampling of my Defections file follows:

1. "VW HIRES FORMER GM EXEC BROWNING AS PART OF SALES DIVISION OVERHAUL" Automotive News, 4 June 2010.
2. "EX-CADILLAC MAN HELPS INFINITI GO GLOBAL" Automotive News, 27 March 2009.
3. "CHRYSLER RECRUITS ANOTHER TOYOTA EXECUTIVE" Automotive News, 2 May 2008.
4. "GM HIRES EX-NISSAN EXEC MCNABB IN SALES REORGANIZATION" Automotive News, 26 Apr 2008.
5. "Chrysler hires Toyota's Meyer to lead global marketing" Automotive News, 15 August 2007.
6. "BIG 3 TALENT JUMPS SHIP TO RIVALS" The Detroit News, 25 April 2005.
7. "DAIMLERCHRYSLER HIGH RANKING OFFICERS LEAVE FOR FORD" Reuters, 1 March 1999.



8. "FORD RECRUITS PLANNER FROM DAIMLERCHRYSLER" Bloomberg News, 1 April 2000.
9. "GM HIRES AWAY PT CRUISER'S DESIGNER FROM DAIMLERCHRYSLER" WSJ, 23 April 2001.
10. "VW NAMES COST-CUTTING FORMER CHRYSLER EXEC TO TAKE OVER MAINSTAY BRAND" Detroit Free Press, 6 October 2004.
11. "DCX EXECUTIVES PINCH-HIT FOR FORD" Automotive News, 16 February 2004.
12. "BRAIN DRAIN: WHY ARE SO MANY TALENTED EXECUTIVES LEAVING FORD" Automotive News, 7 November 2005.
13. "AUDI HIRES MERCEDES MANAGER FOR MARKETING POSITION" Automotive News, 24 May 2006.
14. "FORD COMBATS RAIDS ON TOP DESIGNERS" Automotive News, 7 November 2005.
15. "CHRYSLER DESIGN STAR BOLTS TO FORD" The Detroit News, 2 May 2005.
16. "MITSUBISHI RECRUITS FORD JAPAN CHAIRMAN" Automotive News, 28 May 2002.
17. "GM hires Ford's Devine as CFO" Automotive News, 13 December 2000.
18. "LOVELESS LEAVES CHRYSLER TO JOIN KIA AS SALES CHIEF" Automotive News, 15 June 2007.
19. "MITSUBISHI REPLACES U.S. CEO WITH HYUNDAI'S O'NEILL" The Detroit News, 31 August 2003.
20. "FORMER FORD PR BOSS TO LEAD CHRYSLER PR" Automotive News, 18 December 2003.
21. "DAIMLERCHRYSLER NABS FORD MARKETING PRO" The Detroit News, 21 February 2001.
22. "VOLKSWAGEN CHOOSES FORMER BMW BOSS AS NEW CHIEF EXECUTIVE" The Detroit News, 8 September 2001.
23. "BMW POWERTRAIN LEADER TO HEAD FORD'S GLOBAL R&D" Automotive News, 12 Dec 2000.
24. "ANOTHER FORD MAN WILL TRY TO SAVE MITSUBISHI" Automotive News, 1 April 2005.
25. "DAIMLERCHRYSLER HIRES LEADING GM EXECUTIVE" The Detroit News, 11 May 2000.
26. "VW MIGHT PICK OFF (DAIMLER'S) BERNHARD" Automotive News, 30 August 2004.
27. "NISSAN HIRES VP FROM FORD" Automotive News, 22 May 2003.
28. "OUSTED DAIMLERCHRYSLER EXEC FINDS HOME AT FORD" Automotive News, 26 March 2001.
29. "GM RECRUITS TOYOTA VET AS QUALITY EXPERT" Automotive News, 17 February 2003.
30. "GM VETERAN NAMED PRESIDENT OF TOYOTA" Automotive News, 28 June 2006.

This list of 30 samples is not diatribe; it is meant to serve a relevant point that can be exposed with a few obvious questions:

1. Are we to believe that the inter-automotive company defections, at the highest levels of executive management, are not facilitated by complicity among the corporate defense bar?
2. Are we to believe that the inter-automotive company defections, at all levels of engineering and executive management, were accompanied by “appropriate protective orders” regarding “confidential, proprietary and trade secret information” that was known to be in the possession of these defectors?
3. Are we to believe that recruitment of inter-automotive company defectors, including the highest levels of executive management, targeted only those individuals that were utterly ignorant of “confidential, proprietary and trade secret information”? Or is it well-known that the exact opposite was routinely targeted?

Regarding question #2, I have repeatedly advised plaintiff's, for over sixteen years, to discover such “appropriate protective orders.” None can be legally discovered because none exist (Attachment 4).<sup>6</sup>

### **Chrysler Group relationship with OEM Outside Suppliers (PS-7000)**

Defections of executive management are not restricted to OEM competitors, but extend to the automotive supplier base. A small sampling of that category from my Defections file includes:

- A. “DANA NAMES GM MIKE BURNS CEO” Automotive News, 4 February 2004.
- B. “AUTO SUPPLIER TAPS DAIMLERCHRYSLER EXEC AS CEO” The Detroit News, 18 September 2002.
- C. “HAYES-LEMMERZ HIRES FORMER FORD VP” Automotive News, 23 July 2002.
- D. “GM'S HOGAN DEFECTS TO MAGNA” The Detroit News, 19 August 2004.
- E. “EX FORD EXEC NOW HEAD OF COVARIANT” Automotive News, 28 June 2002.
- F. “FORD'S LIGOCKI LEAVES TO LEAD TOWER” Automotive News, 29 July 2003.
- G. “DELPHI'S ALAPONT LEAVING FOR FIAT TRUCK UNIT” Automotive News, 4 September 2003.
- H. “DURA HIRES FORMER FORD EXEC SZCZUPAK AS COO” Automotive News, 10 December 2006.

In view of defections to & from suppliers, we can also pose the same three questions about “appropriate protective orders.” Again, no such protective orders have ever been sought by the defense bar, and none can be legally discovered.

But an important supplier issue involves Chrysler Group Engineering Standard PS-7000. This public document was first issued in 1979 (after the “Baker memo”).<sup>7</sup> Only minor revisions to PS-7000 have occurred. The Page 12 section “NON-CONFIDENTIALITY” remains in-force:

*“ It is Chrysler’s policy not to enter into formal confidentiality agreements with its suppliers or potential suppliers.*

*To foster the exchange of proprietary information or confidential information, Chrysler and the supplier shall rely on each other’s ethics to handle each other’s proprietary or confidential information in the same manner as each handles its own proprietary or confidential information. ”*

In strict legal terms, the instant that Chrysler documents (such as the “20 engineering drawings” that Mr. Dillon claims are “*subject to the substantial competitive harm standard*”) become the possession of suppliers, said documents become public.<sup>8</sup> Chrysler defense lawyers are fully aware of PS-7000.<sup>9</sup>

The following section provides specificity with respect to Mr. Dillon’s “20 engineering drawings.”

### **Chrysler Group (MOPAR) relationships with Replacement/Aftermarket Suppliers**

The importance, participation and exposure of OEM’s to the replacement/aftermarket industry extends to the Chairman of the Board. For example, both former Chrysler Chairman Robert Eaton and former DaimlerBenz Chairman Jürgen Schrempp were featured on the front cover of SEMA News magazine.<sup>10</sup>

In this context please re-review the 8 January 2010 submission to DP09-005 by Mr. Clarence Ditlow, Director of the Center for Auto Safety (CAS). At their request I had forwarded to CAS pages of the Mitchell International Unibody and Chassis Frame Specifications and Dimensions Manual for the Jeep product line. Please note that I added highlights to emphasize the location and configuration of the defective fuel filler routing issue on ZJ-Body and WJ-Body Jeep Grand Cherokee vehicles.

But importantly, please note the copyright date on the lower portion of the Mitchell International drawings. Note that the 1996 ZJ-Body drawing has a copyright of 1996. Likewise, the 1999 WJ-Body drawing has a copyright of 1999. The 1993 ZJ-Body pages (the first year that the Jeep Grand Cherokee was available) similarly lists a copyright of 1993. Mitchell International, as just one of many aftermarket examples, relied on immediate access to detailed Chrysler drawing information for the purpose of servicing the replacement and aftermarket arena. Their well-known role is the dissemination of detailed specifications and design details which facilitate the work product of replacement and aftermarket suppliers for Chrysler vehicles. A prominent example, that is well-known to Chrysler defense lawyers, is the aftermarket manufacture and sale of Jeep Grand Cherokee skid plates.

In other words, the information contained on the “20 engineering drawings” that Mr. Dillon now claims “*is subject to the substantial competitive harm standard*” because “*competitors could use this design information to improve their own designs*” has continuously been in the public domain concurrent with each model-year introduction of the ZJ-Body and WJ-Body. This is consistent with the fact that PS-7000 also applies to the replacement/aftermarket part suppliers to Chrysler/MOPAR (Attachment 5).

### **Conclusions and Opinion**

In my experience, the concept and legal enforcement of “trade secrets” in Detroit is entirely dependent on the context, and who/what are involved. You should react with suspicion when repeatedly confronted with the reality that so-called confidential information is alleged as such but only when either or both of the following categories are involved:

- i. Product liability litigation
- ii. NHTSA Safety Defect Investigations

But since he is an active defense witness in existing Jeep Grand Cherokee product litigation, the request made by Mr. David D. Dillon on 15 October 2010 involves both categories. Given the six main topics presented above, Mr. Dillon’s claim that 25 year-old data is somehow being sought by competitors is beyond absurd; it is insulting on many levels. In my opinion you should deny the Chrysler Group LLC request that such information receive confidential treatment on at least one crucial basis:

The alleged competitors would not view information that they already have in their possession as “trade secrets.” In this instance, they would view the “*20 engineering drawings*” as confirmation of how **not** to design a fuel system.

Consequently, release of this information could save lives.

Respectfully and sincerely yours,

Paul V. Sheridan

Enclosures/Attachments

## ENDNOTES

---

<sup>1</sup> Regarding PE10031, it is ostensibly suggested Chrysler defense lawyers and internal government relations staff that a massive intercontinental strategic nuclear weapons certified bomber could be reverse engineered, but regarding the 1993 thru 2004 Jeep Grand Cherokee “*reverse engineering is impossible.*”

<sup>2</sup> In the 1970’s I was a personal friend of Dr. Frederick Arlotta, then Chief Systems Engineer at Grumman Aerospace in Bethpage, L.I., New York; assigned to the F-14 Tomcat program. I have been versed in the process of anti-reverse engineering for four decades.

<sup>3</sup> Please review NHTSA file EA94-005.

<sup>4</sup> Unless I am mistaken, the Kline death accident was an example of a highway accident statistic that was not originally included in the FARS data base.

<sup>5</sup> While working for the Dodge Truck Operation Group I reported to and frequently communicated one-on-one with Mr. Lutz.

<sup>6</sup> A typical further example is my former JTE supervisor, Mr. Chris Theodore. He originally worked for Ford Motor Company. Then he worked for General Motors. Then he worked for American Motors Corporation. Then he worked for Chrysler Corporation. After turning down employment solicitation from Nissan, he again worked for Ford Motor Company in 1999. In 1999 Theodore was interviewed by the Automotive News, and stated: “*There are no trade secrets in Detroit.*” Then he worked for at least two different outside suppliers to the Detroit automotive companies. (Mr. Theodore was also the Minivan Platform Engineer during EA94-005, who had insisted, contrary to my SLT, that the Chrysler AS-Body minivan single-stage liftgate latch, which could not comply with FMVSS-206, was not defective. However, Mr. Theodore never volunteered nor appeared to testify in open court regarding his technical rationale/justification for his opinion.)

<sup>7</sup> Please see Enclosure 4/Attachment 3 of the Paul V. Sheridan letter of 9 February 2011 to Mr. David L. Strickland.

<sup>8</sup> Ignore the watermark, placed by Chrysler defense lawyers, which claims that PS-7000 is subject to a protective order; it is not. Like the documents and information described therein, PS-7000 itself is routinely and firstly shared with outside suppliers and merely potential suppliers. The watermark ostensibly but falsely proclaims that a working document that declares non-confidentiality, is confidential (?). It is also common for Chrysler defense lawyers to routinely make documents as if subject to a protective order while being fully aware that such has/have already been in the public domain for years/decades. I have worked with many plaintiffs that were initially tricked by this ruse.

<sup>9</sup> As you are aware, the relationship between the OEM manufacturer and the outside supplier is so close that the latter is self-certified with respect to regulatory compliance with the Transportation Safety Act.

<sup>10</sup> As Chrysler Group LLC defense lawyers are fully aware, I am very active in the replacement and aftermarket (e.g. motorsports) arena. I am a 25-year member of the Specialty Equipment Market Association (SEMA), an annual attendee at the Performance and Racing Industry (PRI) show; I work on and maintain my own vehicles, and have built and driven national record holding race vehicles that have been featured in many automotive enthusiast magazines, etc.

# Attachment 1



**CHRYSLER**

NHTSA  
WASHINGTON, DC 20590

2010 OCT 18 P 4: 35

OFFICE OF CHIEF  
COUNSEL

David D. Dillon  
Sr. Manager  
Product Investigations & Campaigns

October 15, 2010

Mr. O. Kevin Vincent  
Chief Counsel  
National Highway Traffic Safety Administration  
1200 New Jersey Ave., SE, Room W41-227  
Washington, DC 20590

Re: Request for Confidential Treatment of Business Information Submitted in PE10-031

Dear Mr. Vincent:

Chrysler Group LLC ("Chrysler") is submitting information to the NHTSA Office of Defects Investigation (ODI) in connection with the above referenced investigation. Based on a careful review of the submission, Chrysler Group has determined that some of the information is confidential and should be accorded confidential treatment under this agency's regulations at 49 C.F.R. Part 512 and Exemption 4 of the Freedom of Information Act ("FOIA"), 5 U.S.C. § 552(b)(4).<sup>1</sup> Therefore, Chrysler Group is submitting the enclosed CDs together with this request for confidential treatment to the Office of Chief Counsel.

The information required by Part 512 is set forth below.

**A. Description of the Information (49 C.F.R. § 512.8(a))**

The business information for which confidential treatment is being sought is 20 engineering drawings in Enclosure 4 CONF BUS INFO (Bates page #PE10-031-Chrysler-000001 - 000089).

**B. Confidentiality Standard (49 C.F.R. § 512.8(b))**

This submission is subject to the substantial competitive harm standard set forth in 49 C.F.R. § 512.15(b) for information that a submitter is required to provide to the agency.

<sup>1</sup> Chrysler Group has taken steps to assure that the CDs are free of any errors or defects that would prevent NHTSA from opening the files on the discs. If, however, the agency is unable to open the files, Chrysler Group respectfully requests that the agency inform Chrysler Group of the issue, so that Chrysler Group may take steps to supply NHTSA's Office of Chief Counsel with a disc that is fully functional.

**C. Justification for Confidential Treatment (49 C.F.R. § 512.8(c))**

This agency's regulations and Exemption 4 of the Freedom of Information Act ("FOIA"), 5 U.S.C. § 552(b)(4), protect the confidentiality of information that would be likely to cause substantial competitive harm to the submitter if disclosed. *See, e.g.* 49 C.F.R. § 512.15(b) *National Parks & Conservation Ass'n v. Morton*, 498 F.2d 765, 770 (D.C. Cir. 1974). FOIA Exemption 4 was enacted to prevent disclosures that would "eliminate much of the time and effort that would otherwise be required to bring to market a product competitive with the [submitter's] product." *Public Citizen Health Research Grp. v. FDA*, 195 F.3d 898, 905 (D.C. Cir. 1999) "Because competition in business turns on the relative costs and opportunities faced by members of the same industry, there is a potential windfall for competitors to whom valuable information is released under FOIA. If those competitors are charged only minimal FOIA retrieval costs for the information, rather than the considerable costs of private reproduction, they may be getting quite a bargain. Such bargains could easily have competitive consequences not contemplated as part of FOIA's principal aim of promoting openness in government." *Worthington Compressors, Inc. v. Costle*, 662 F.2d 45, 51 (D.C. Cir. 1981). Substantial competitive harm also may result from disclosures that would reveal a firm's "operational strengths and weaknesses" to competitors. *See Nat'l Parks & Conservation Ass'n v. Kleppe*, 547 F.2d 673, 684 (D.C. Cir. 1976). The information at issue here should be protected under these standards.

The engineering drawings contain the detailed design specifics for various components of two vehicles. Competitors could use this design information to improve their own designs without incurring the time and expense associated with independent design efforts. As a result, Chrysler Group's competitors could bring to market their products much quicker and at less cost.

**D. Class Determination (49 C.F.R. § 512.8(d))**

The engineering drawings fall within the class determination for "blueprints and engineering drawings." 49 C.F.R. Part 512, App. B(1).

**E. Duration for Which Confidential Treatment is Sought (49 C.F.R. § 512.8(e))**

Because Chrysler Group anticipates that the information will be competitively valuable indefinitely, Chrysler Group requests that the information be accorded confidential treatment permanently.

**F. Contact Information (49 C.F.R. § 512.8(f))**

Please direct all inquiries and responses to the undersigned at:



800 Chrysler Drive, CIMS 482-00-91  
Auburn Hills, MI 48326  
248-512-0087  
dd28@chrysler.com

\*\*\*

If you receive a request for disclosure of the information for which confidential treatment is being sought before you have completed your review of our request, Chrysler respectfully requests notification of the request(s) and an opportunity to provide further justification for the confidential treatment of this information, if warranted.

Sincerely,

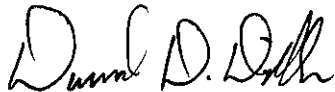

David D. Dillon

cc: Scott Yon  
Lawrence Hershman

Attachment and Enclosures

### Certificate in Support of Request for Confidentiality

I, David D. Dillon, pursuant to the provisions of 49 C.F.R. Part 512, state as follows:

- (1) I am Chrysler Group LLC's Senior Manager, Product Investigations & Campaigns and I am authorized by Chrysler Group LLC to execute documents on its behalf;
- (2) I certify that the information contained in the attached documents is confidential and proprietary data and is being submitted with the claim that it is entitled to confidential treatment under 5 U.S.C. 552(b)(4);
- (3) I hereby request that the information contained in the indicated documents be protected on a permanent basis;
- (4) This certification is based on the information provided by the responsible Chrysler Group LLC personnel who have authority in the normal course of business to release the information for which a claim of confidentiality has been made to ascertain whether such information has ever been released outside Chrysler Group LLC;
- (5) Based upon that information, to the best of my knowledge, information and belief, the information for which Chrysler Group LLC has claimed confidential treatment has never been released or become available outside Chrysler Group LLC, except to certain contractors of Chrysler Group LLC with the understanding that such information must be maintained in strict confidence;
- (6) I make no representations beyond those contained in this certificate and, in particular, I make no representations as to whether this information may become available outside Chrysler Group LLC because of unauthorized or inadvertent disclosure (except as stated in paragraph 5); and
- (7) I certify under penalty of perjury that the foregoing is true and correct.

Executed on this 15<sup>th</sup> day of October, 2010

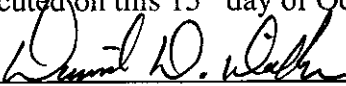
  
\_\_\_\_\_  
David D. Dillon

# Attachment 2



# Inter Company Correspondence

Code

Date

(sentra)

June 14, 1991

To-Name & Department

CIMS Number

**SEE BELOW**

From-Name & Department

CIMS Number

D. M. Fitzpatrick	Manager- Technical Cost Planning	Chrysler Center	414-08.
-------------------	-------------------------------------	--------------------	---------

Subject

TO: R.R. Boltz  
F.J. Castaing  
J.G. Damoose  
T.C. Gale  
R.A. Lutz

D.K. Pawley  
T.R. Cunningham  
T.W. Sidlik  
T.T. Stallkamp  
G.C. Valade

## 1991 Nissan Sentra E - Design Cost Study

As a follow-up to the May 12, 1991 teardown review of the 1991 Sentra, you will find attached a cost comparison to the 1994 1/2 PL-Body.

As the cost summary shows, it is estimated that on a design basis the cost of the Sentra exceeds the PL by approximately \$185. Adjusting for the difference between the PL driver and passenger side air bag system and the Sentra motorized seat belt system, the design cost of the Sentra is approximately \$385 over the PL.

Sentra has a number of interesting features that are summarized on page 2.

The contents of this report are:

	<u>Page</u>
• Overview - "Sentra Features"	2
• Dimensional Comparison	3
• Weight Comparison	4
• Summary of NVH Items	5
• Potential Cost Reduction Items	6
• Cost Summary	7
• Detailed Cost Analysis	8

The sectioned shell and all individual components are in the Competitive Teardown area in the basement of the W.P. Chrysler Building.

*D.M. Fitzpatrick*  
D.M. Fitzpatrick

Attachments

cc: Distribution List

## **SENTRA FEATURES**

The Sentra was extremely quiet and "stiff" feeling for a \$9,300 car. Dis-assembly showed several NVH and body structural items that were on \$30,000 to \$40,000 cars that contributed to the vehicle's solid feeling.

- **Dash Panel Doubler** - a NVH item made from a mastic backed .026 steel panel that extends from plenum to front floor pan and wheelhouse to wheelhouse.
- **Floor pan mastic** is used with varying thicknesses on the front and center floor, plus, beneath the rear seat cushions. There are additional patches on the cowl plenum lower panel, in the trunk spare tire well and on the rear wheelhouses. Unique is the double layer of mastic on the tunnel at the rear seat cushion and an additional insulator of different material on the floor pan at the rear seat cushion front edge.
- This is the first vehicle that we have dis-assembled that has a hydraulically dampened right side engine mount with three other more "standard" type mounts, an added anti-roll lever and a dedicated isolated engine mount (north/south) crossmember.
- All plastic to plastic contacts in the instrument panel, garnish/trim moldings, console and door pull panels have anti-squeak strips.
- Triple door seals are used, including; a full door surround, door opening upper flange cover and weather seal assembly, and a seal and drip edge that extends from the A-pillar, along the roof and down the C-pillar. (Sentra also has a door to door seal at the B-pillar to close the gap between the doors from the belt to the roof).
- Vehicle stiffness has been accomplished by the use of many frame rail doublers, crossmember reinforcements, added floor pan components and well engineered body panels.
- The Sentra has a two position cam timing system consisting of hydraulic activated helical gears that are activated by an electro-hydraulic solenoid which is monitored by the engine controller.
- The pistons are molybdenum coated for reduced friction.
- A dual chain cam drive system for improved valve train and cylinder head packaging.

# Attachment 3



# Inter Company Correspondence

Telephone

Date

776-2909

January 27, 1993

To-Name & Department

CIMS Number

Please See Below

From-Name & Department

CIMS Number

R. A. Winter

General Product Manager - Minivan Operations C.T.C.

482-08-02

Subject:

## Minivan Safety Leadership Team (SLT)

TO: D.P. Bostwick  
T.M. Creed  
D.E. Dawkins  
R.L. Franson

M.R. Levine  
T.S. Moore  
J.W. Rickert  
P.M. Rosefeld

S.T. Rushwin  
F.I. Sanders  
R.A. Sarotte  
C.P. Theodore  
S.A. Torok

Safety has been an important consideration among Minivan buyers, and Chrysler has enjoyed a leadership position with the implementation of driver's air bag and child seats. The competition has passed us in 1993 by meeting passenger car safety standards, but we will retake the lead in 1994 with passenger side air bags.

In order to maintain our leadership position in this segment we need to provide a vehicle that has the most important safety attributes, and to that end the Minivan Safety Leadership Team is being formed. The purpose of the team is to re-establish Chrysler's advertisable safety leadership position, with particular emphasis on the NS-Body. The general format will focus effort in the areas of "Accident Avoidance", "Accident Survival" and other security issues, and the team will avail itself to all sources of expertise/assistance.

Attached is the current membership listing. Your support/awareness of this activity will enhance the ability of the team in this extremely important task. Your comments are welcome.

R.A. Winter

/sem  
RAW#8\sltmemo

Attachment

**NS-BODY  
SAFETY LEADERSHIP TEAM (SLT)**

- **Background**

- Through its aggressive implementation of the air bag, and other safety related features, Chrysler enjoyed an advertisable safety leadership position through the 1990/1991 timeframe.
- Current and projected competitive activity in the area of safety will erode our leadership position to that of parity, especially in the minivan segment.

- **Purpose/Mission Statement**

- Accurately assess our current and projected status in the area of safety, using the following as a basis for discussion:
  - ▶ 1995 AS-Body exit levels
  - ▶ Documentation/specification of regulatory compliance plans
- Define specific additional requirements/actions to re-establish an advertisable leadership position.
- Focus will be on the NS-Body and the minivan segment, but SLT activity will be formatted to be transferrable/accessible to other platforms.
- Monitor safety innovations.
- Monitor competitive activity.
- Establish/monitor consumer acceptance.

- **Format**

- It is proposed that the SLT examine the safety leadership issue in the context of the following categories:
  - ▶ Accident Avoidance
    - ABS
    - Traction Control/Enhancement
    - Speed Dependent Steering
    - Active Suspension
    - Driver Information Enhancement



- **Format (continued)**

- ▶ **Accident Avoidance (continued)**
  - Exterior Lighting/Signaling
  - Mirrors/Visibility
  - Back-up Alert
  
- ▶ **Accident Survivability**
  - Air Bags (Active)
  - Occupant Restraints (Passive and Active)
  - Crash Management
  - Crash Intrusion
  - Bumper Integrity
  - Side Impact
  - Roof Crush
  - Rollover
  - Seat Back Strength
  - Headrests
  - Glass Retention
  
- ▶ **Other**
  - Anti-theft
  - Security Systems
  - Mechanical Reliability
  - Communications
  - Comfort (anti-fatigue)
  - IVHS

- **Organization/Membership**

- |                              |                                    |
|------------------------------|------------------------------------|
| ● Minivan Operations (Chair) | ● Liberty                          |
| ● Safety Office              | ● Marketing                        |
| ● Engineering                | ● Sales                            |
| ● International Operations   | ● Design Office                    |
|                              | ● Competitive Information Activity |

- ▶ Additional organization involvement will occur as appropriate.

- **Other**

- To be effective, the SLT will require empowerment via executive level recognition of the SLT mission, and resultant dedication of staff support.
- Meeting time tentatively set to alternate with existing Minivan Complexity Team on Tuesdays, 8:15 - 9:00 a.m.
- Initial agenda priority will be review of the NS-Body ABS strategy.

**NS-BODY  
SAFETY LEADERSHIP TEAM (SLT)**

**MEMBERSHIP**

<b><u>Organization</u></b>	<b><u>Representatives</u></b>	<b><u>CIMS</u></b>	<b><u>Telephone</u></b>	<b><u>Telefax</u></b>
Minivan Operations *	Paul V. Sheridan	482-08-02	776-4824	776-2261
Safety Office	Ronald S. Zarowitz	415-03-21	876-1126	822-5069
Engineering	TBD			
International Operations	Gregory A. Blindu	415-03-05	876-5983	876-4752
Liberty	TBD			
Marketing	William H. Hines (Dodge) Mark W. Clemons (C/P)	414-04-40 414-04-35	876-5523 876-3763	822-6957 822-6957
Sales	James L. Boeberitz	414-05-29	876-3942	822-7431
Design	TBD			
Competitive Information Activity	Michael T. Delahanty	414-02-16	876-1464	876-4241

\*Chair

# Attachment 4



# Inter Company Correspondence

Telephone

Date

August 16, 1990

To -- Name & Department

CIMS Number

## All Executive Engineers

From -- Name & Department

CIMS Number

H. W. Roush

Group Human Resources Manager -  
Vehicle Engineering and Product Design

418-01-31

Subject:

### POINTS FOR COMMUNICATIONS

#### 1. Recruiting - as of 8/15/90

- . July 8 newspaper ad -- 334 responses -- 103 resumes referred to operating levels.
- . August 8 Lendman Career Fair -- 271 interviewed -- 58 resumes referred to operating levels.
- . 15 Engineers have been in for interview to date.
- . Ad for NVH Specialists will run in "Sound and Vibration" Trade Magazine - September issue.

#### 2. Resignations

As of August 3 -- our total for the year was 69 -- compared to 73 for all of 1989. 31 of the 69 have gone to Ford.

#### 3. Engineers in the News

- . In a special issue of Ebony (August, 1990), Vera Trueblood, an engineer in the Minivan Platform group, is profiled as a successful role model who was recognized as a cost conscience team player by winning the 1989 Chairman's Award. She is a member of Vehicle Engineering's Minority Recruiting team and is also a member of the Board of Directors for the Detroit Urban League.
- . The 1990 International Symposium on Electromagnetic Compatibility will be held in Washington, D.C. from August 21 to 23. This gathering will showcase a research paper co-authored by James P. Muccioli and Scott Ashley. Mr. Muccioli, Scott's supervisor, is part of Small Car Platform under D. E. Florence's group. Mr. Ashley is a Chrysler Institute of Engineering (CIE) student.

#### 4. General Communications

The only certainty about communications is that "information" gets passed around every day. Rumors start when people do not know the facts and the reasons behind the facts.

It is not always easy to communicate facts to all areas of the work force -- and - even when we are able to do that -- circumstances can change and the application of factual information will sometimes vary in response to the changes.

We need to continue the emphasis on communications and pass along balanced news. The future of our Corporation is bright and we must continue to emphasize that fact.

Consider some points communicated by Chris Theodore in recent employee meetings:

- . The current situation isn't even close to 1980. What we tend to forget is that many of our people were not here in 1979/1980 -- so this is a new and disconcerting time for them.
- . The last eight years of prosperity is unprecedented in American automotive history.
- . For those people too young to remember - the auto industry has been historically cyclical -- a downturn approximately every four years.
- . Chrysler has the most dedicated product development plan in its history. Most major new products will be domestically engineered. Strategic emphasis is on the automobile manufacturing business.
- . We are dedicated to our people and are making every effort to keep them.
- . We are communicating more with employees and attempting to understand and address their concerns and problems.
- . With our organization in transition, there is a lot of misinformation going around. When you hear or read something -- stop and consider the source -- do the facts support the conclusion? -- does it make sense? --- when in doubt ask your supervisor -- we are committed to getting you an answer.



H. W. Roush

bk

cc:

J. Bahm  
 F. Castaing  
 T. Gallagher  
 C. Gardner  
 J. Mallebay-Macqueur  
 R. P. Marcell

T. Moore  
 J. Nemeth  
 B. Robertson  
 R. Rossio  
 R. Torigian  
 S. Unger

communic.hwr

# Attachment 5

**Howell, Rosa (NHTSA)**

---

**From:** Hershman, Larry (NHTSA)  
**Sent:** Tuesday, January 12, 2010 9:28 AM  
**To:** Howell, Rosa (NHTSA)  
**Cc:** Yon, Scott (NHTSA)  
**Subject:** FW: Jeep Grand Cherokee Fuel System Petition

Rosa,  
Here is another supplement to the Jeep Grand Cherokee petition, file # DP09-005, for inclusion into Artemis.  
Thanks,  
Larry

---

**From:** Demeter, Kathleen (NHTSA)  
**Sent:** Monday, January 11, 2010 11:47 AM  
**To:** Hershman, Larry (NHTSA)  
**Subject:** FW: Jeep Grand Cherokee Fuel System Petition

[Another submission](#)

---

**From:** Clarence Ditlow [mailto:cmdiii@autosafety.org]  
**Sent:** Friday, January 08, 2010 9:58 PM  
**To:** Demeter, Kathleen (NHTSA)  
**Cc:** Yon, Scott (NHTSA)  
**Subject:** Jeep Grand Cherokee Fuel System Petition

Please include and consider in our petition the attached drawings scanned from the Mitchell International 'Unibody and Chassis Frame Specifications and Dimensions Manual.' These manuals are used routinely inside the automotive OEM and repair/service industry.

Please note the mark-ups of the Jeep frame section drawings that depict the location (or lack-thereof) of the fuel filler tube pass-thru holes. The yellow comment boxes have been added only to highlight the subject locations.

At the Center's request, Paul Sheridan has personally inspected many model-year versions of Jeep Cherokee and Jeep Grand Cherokee vehicles to confirm that the fuel filler tube is made of rubber and passes through the frame rail in 1993-98 Jeep Grand Cherokees and under the frame rail in 1999-04 Jeep Grand Cherokees. We are sending out another investigator to examine Grand Cherokees in Florida to confirm this information. Also attached are detailed photos of the steel filler neck, the rubber filler tube and the plastic tank in the Grand Cherokee examined by MVFRI.

This is a defective design of the fuel filler tube whose performance is not measured by FMVSS 301.

Please do not hesitate to contact me as needed.

Paul Sheridan

Clarence Ditlow  
Executive Director  
Center for Auto Safety  
1825 Connecticut Ave NW  
Washington DC 20009

DP09-005  
ATTACHMENT



Fig. 2 Frame Alignment Reference Dimensions—XJ Vehicles

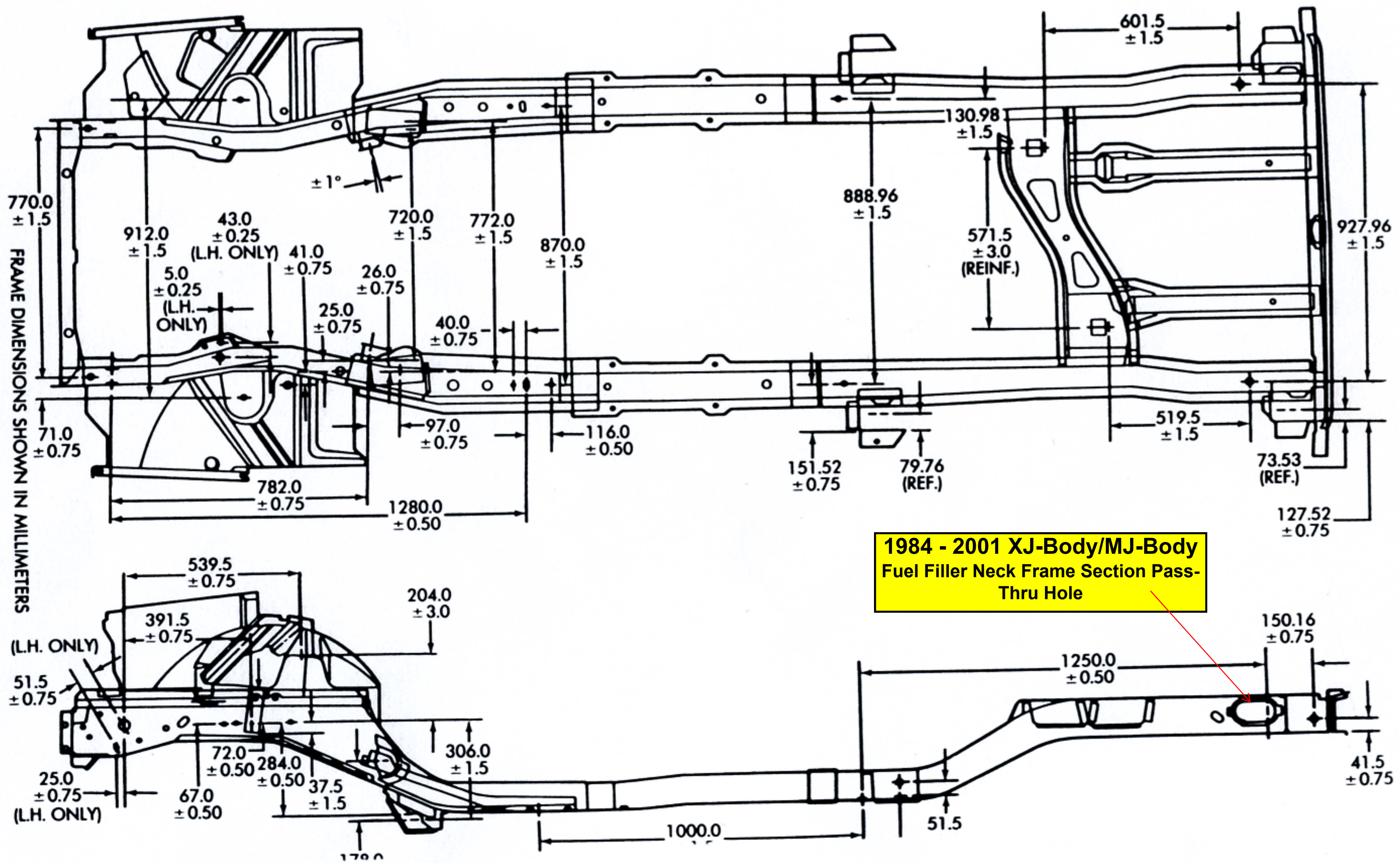

# 1996 JEEP GRAND CHEROKEE 2WD/4WD

105 15/16" (2691mm) WHEELBASE

## UNDERHOOD VIEW

UNDERHOOD VIEW POINT-TO-POINT DIMENSIONS ARE TAKEN WITH TRAM BAR POINTERS SET AT EQUAL LENGTHS. Bolts and Studs are Measured to Center. Holes are Measured to Closest Edge.

## BOTTOM VIEW

BOTTOM VIEW POINT-TO-POINT DIMENSIONS ARE TAKEN WITH TRAM BAR POINTERS SET AT EQUAL LENGTHS. Bolts and Studs are Measured to Center. Holes are Measured to Closest Edge.

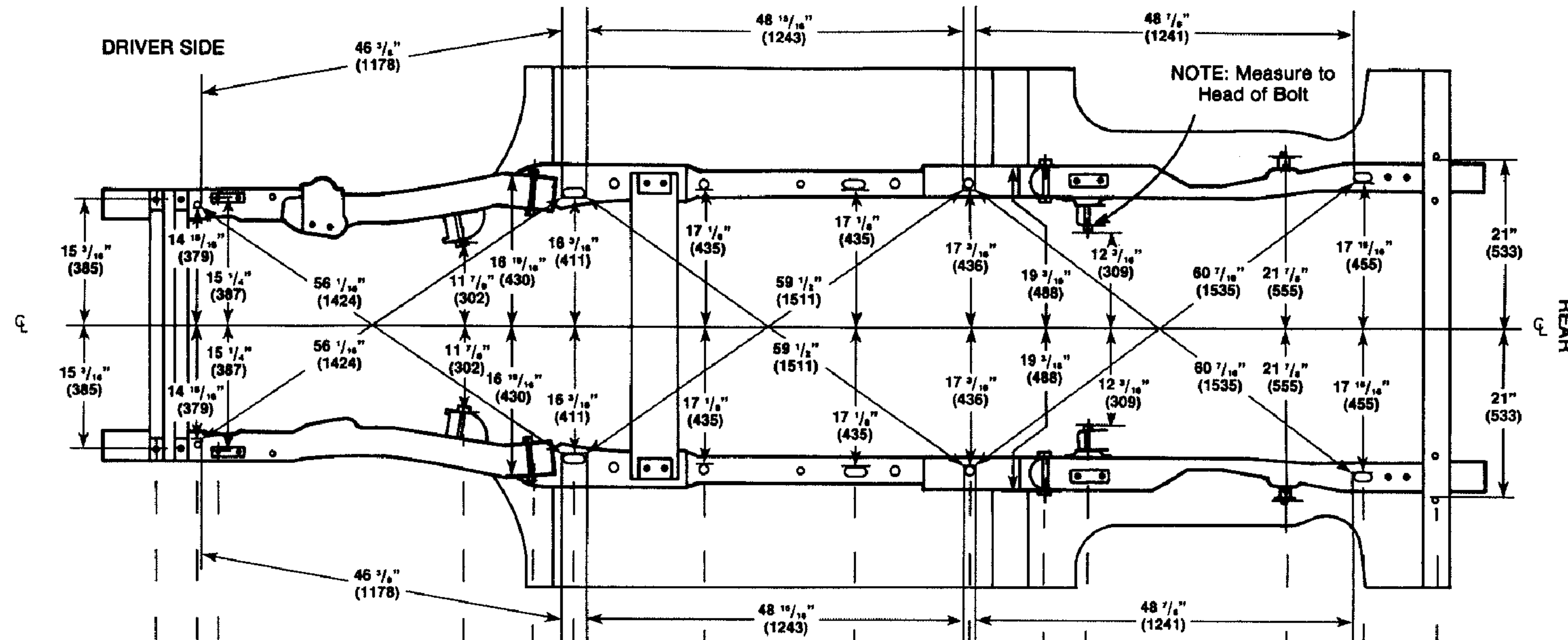
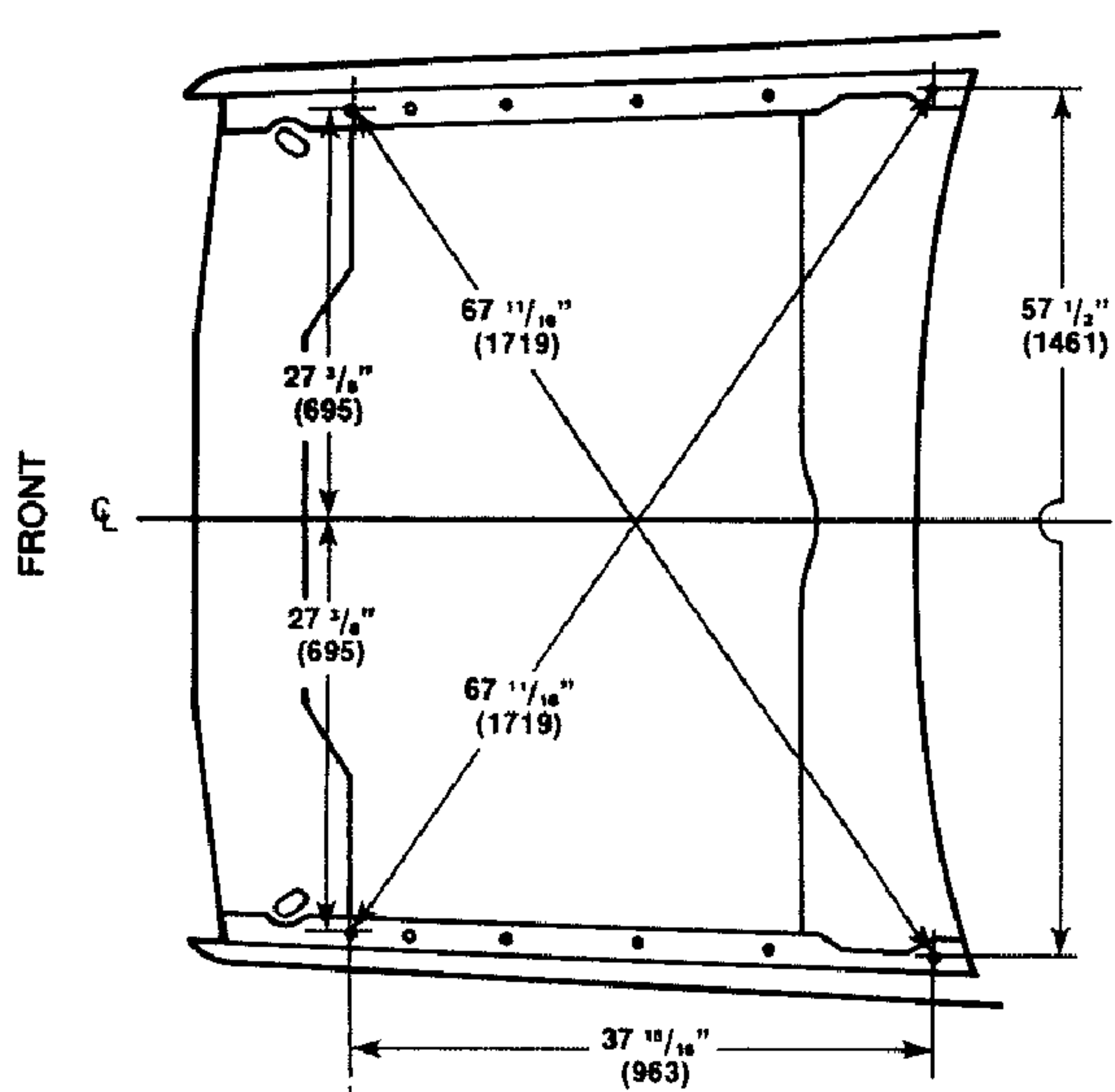

**1993-1998 ZJ-Body:**  
Fuel Filler Tube  
Frame Section  
Pass-Thru Hole

See "C" for Datum Height and Length

Top of Front Fender Bolt on Core Support

## SIDE VIEW

Datum Height Dimensions are PERPENDICULAR to Datum Plane. Datum Length Dimensions are PARALLEL to Centerline of Vehicle, and are Measured Center-to-Center.

### MEASURING POINTS

- A = Bolt
- B = 3/16" (14) - Threaded Hole
- C = Front Fender Bolt
- D = Bolt
- E = Bolt
- F = Bolt
- G = 3/8" x 1" (19 x 25)
- H = 3/4" (19)
- I = 3/8" x 1" (19 x 25)
- J = 3/4" (19)
- K = Bolt
- L = Bolt
- M = Bolt
- N = 3/4" x 1" (19 x 25)
- O = 1/2" (13)

OVERALL DATUM LENGTHS  
B to G = 46 1/8" (1175mm)  
G to J = 49 3/4" (1264mm)  
J to N = 49 3/16" (1250mm)

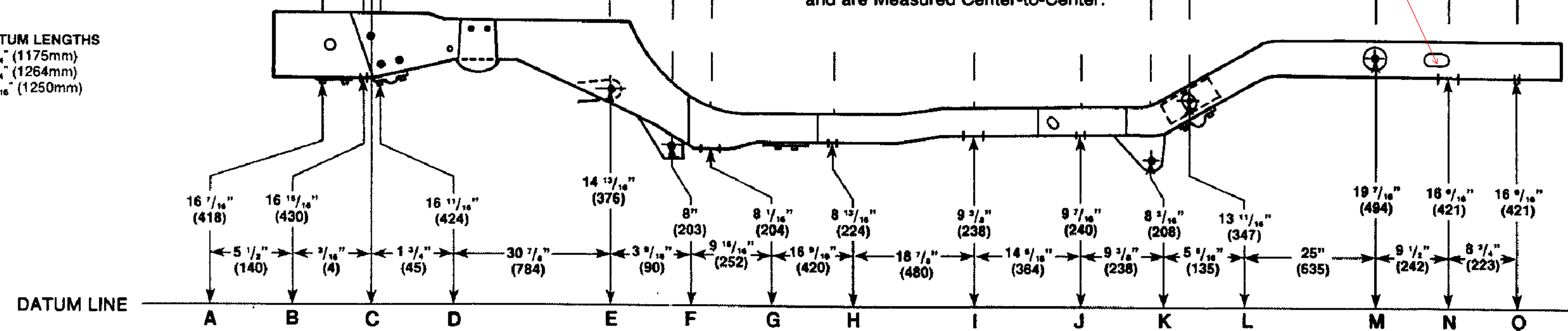

SEE PROCEDURE EXPLANATION

**UNDERHOOD VIEW**  
 UNDERHOOD VIEW POINT-TO-POINT DIMENSIONS ARE TAKEN WITH TRAM BAR POINTERS SET AT EQUAL LENGTHS. Bolts and Studs are Measured to Center. Holes are Measured to Closest Edge.

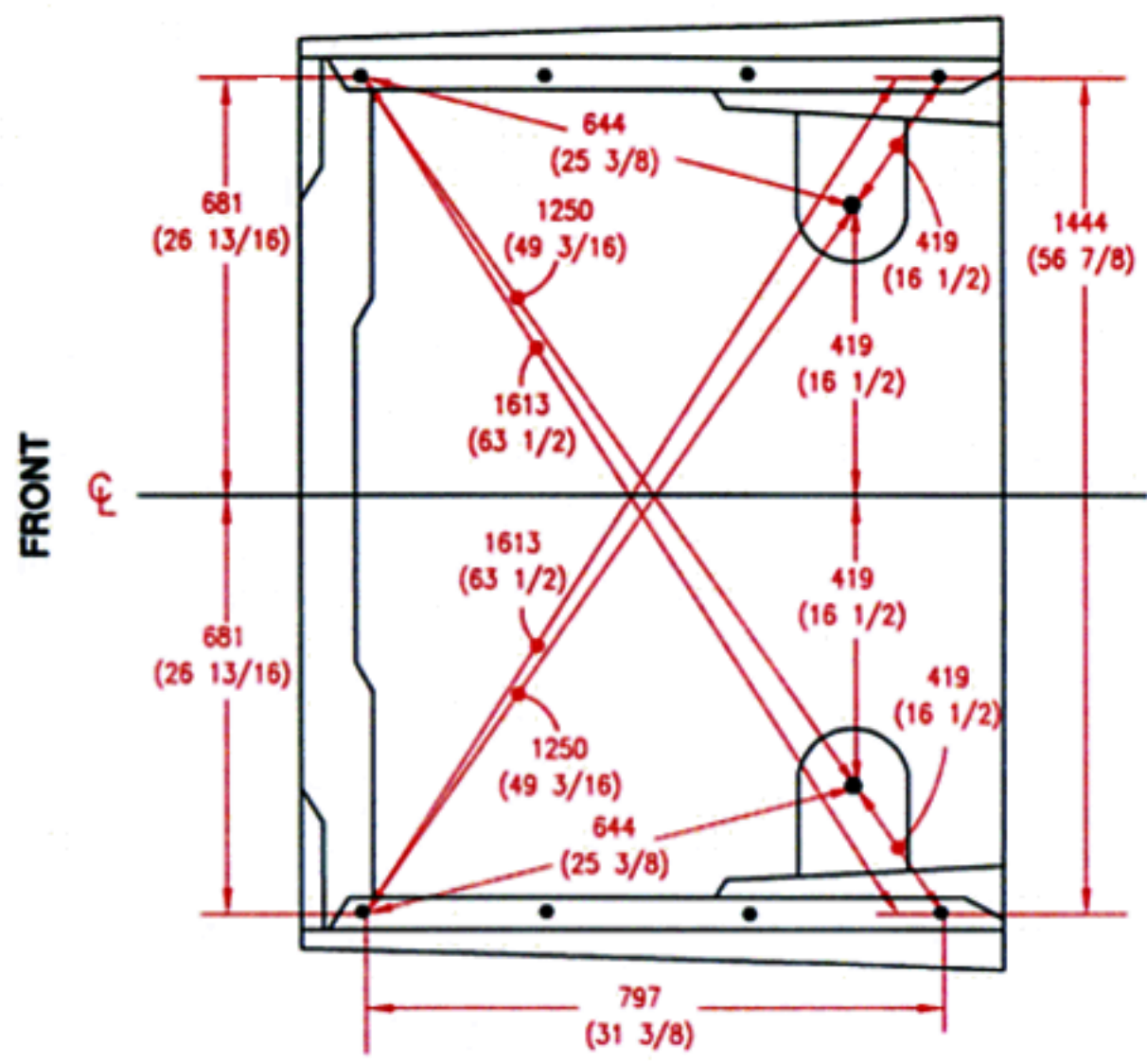

See "C" for Datum Height and Length

**BOTTOM VIEW**  
 BOTTOM VIEW POINT-TO-POINT DIMENSIONS ARE TAKEN WITH TRAM BAR POINTERS SET AT EQUAL LENGTHS. Bolts and Studs are Measured to Center. Holes are Measured to Closest Edge.

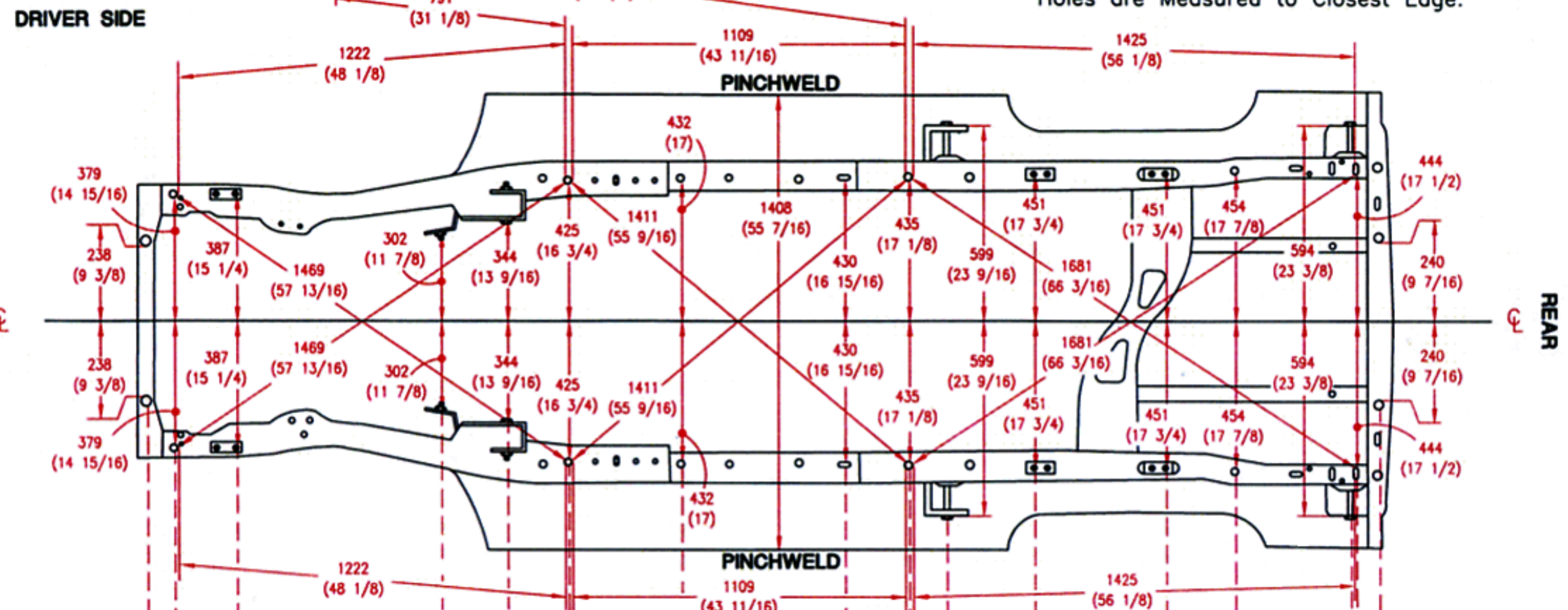

Top of Front Fender Bolt on Core Support

1999-2001 XJ-Body:  
 Fuel Filler Tube Pass-Thru Hole DELETED from Frame Section;  
 Fill Tube Routing Revised to 'Under-Frame' Configuration

**MEASURING POINTS**

- A = 26 (1)
- B = 16 (5/8)
- C = Front Fender Bolt
- D = Bolt
- E = Bolt
- F = Bolt
- G = 19 (3/4)
- H = 19 (3/4)
- I = 26 x 32 (1 x 1 1/4)
- J = 19 (3/4)
- K = Bolt
- L = Bolt
- M = Bolt
- N = 19 (3/4)
- O = Bolt
- P = 13 x 20 (1/2 x 13/16)
- Q = 22 (7/8)

**OVERALL DATUM LENGTHS**  
 B to G = 1224 (48 3/16)  
 G to J = 1128 (44 7/16)  
 J to P = 1430 (56 5/16)

**SIDE VIEW**  
 Datum Height Dimensions are PERPENDICULAR to Datum Plane. Datum Length Dimensions are PARALLEL to Centerline of Vehicle, and are Measured Center-to-Center.

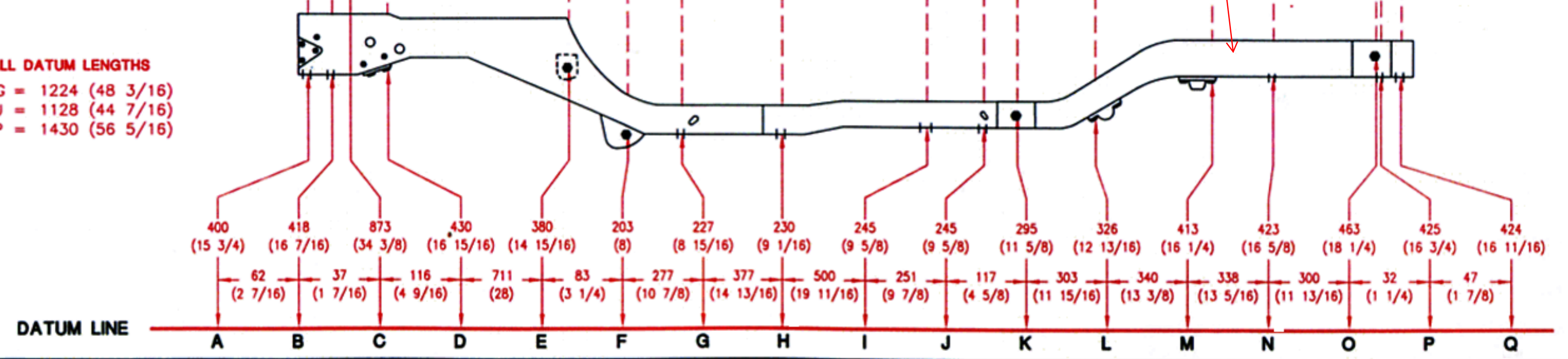

# 1999 JEEP GRAND CHEROKEE 4WD

2690 (105 7/8) WHEELBASE

**UNDERHOOD VIEW**  
 UNDERHOOD VIEW POINT-TO-POINT DIMENSIONS ARE TAKEN WITH TRAM BAR POINTERS SET AT EQUAL LENGTHS. Bolts and Studs are Measured to Center. Holes are Measured to Closest Edge.

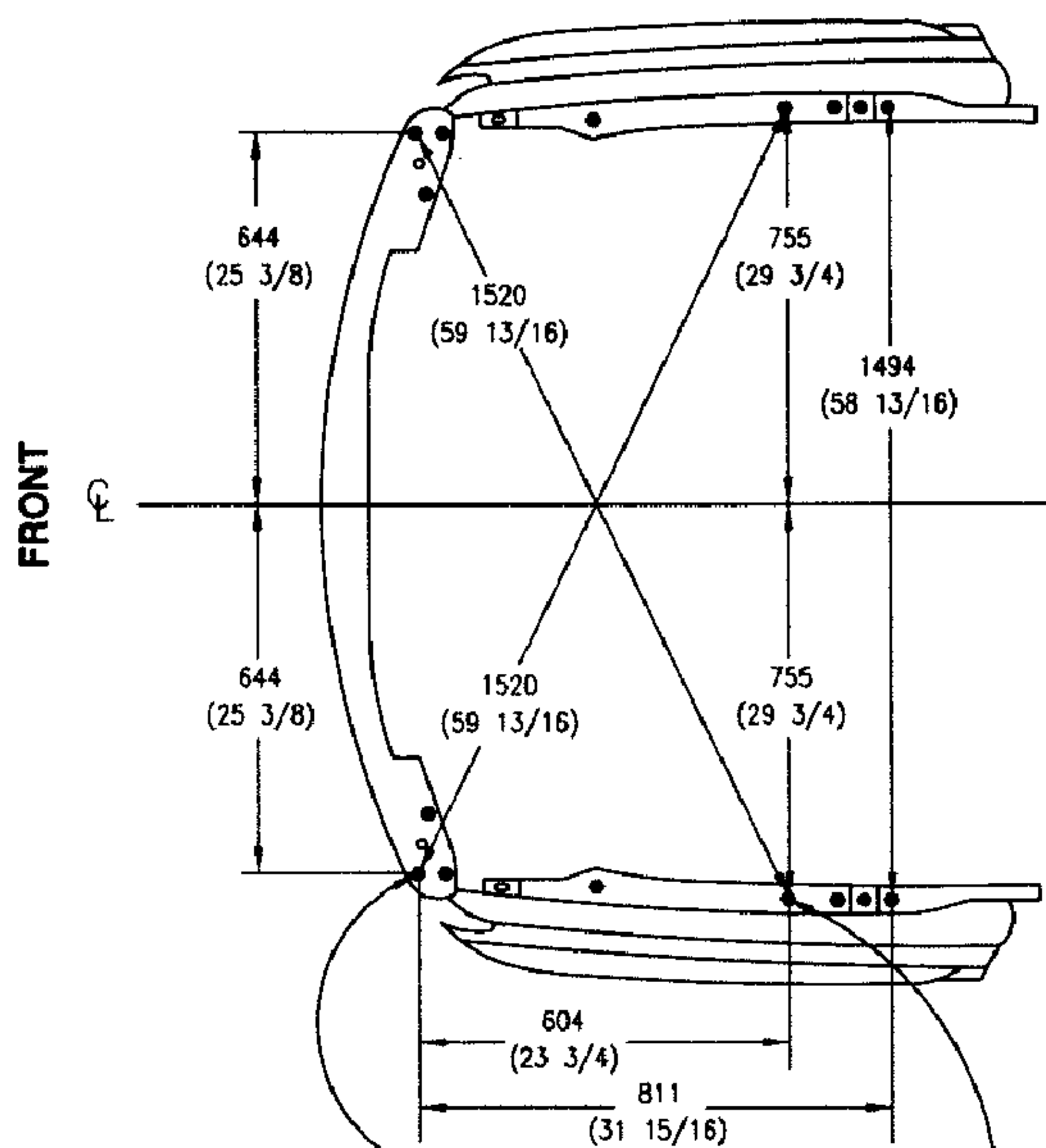

See B for Datum Height and Length

See D for Datum Height and Length

**NOTICE**  
 All Dimensions to Bolts ON THIS PAGE are Measured to Head or Tip.

**BOTTOM VIEW**  
 BOTTOM VIEW POINT-TO-POINT DIMENSIONS ARE TAKEN WITH TRAM BAR POINTERS SET AT EQUAL LENGTHS. Bolts and Studs are Measured to Center. Holes are Measured to Closest Edge.

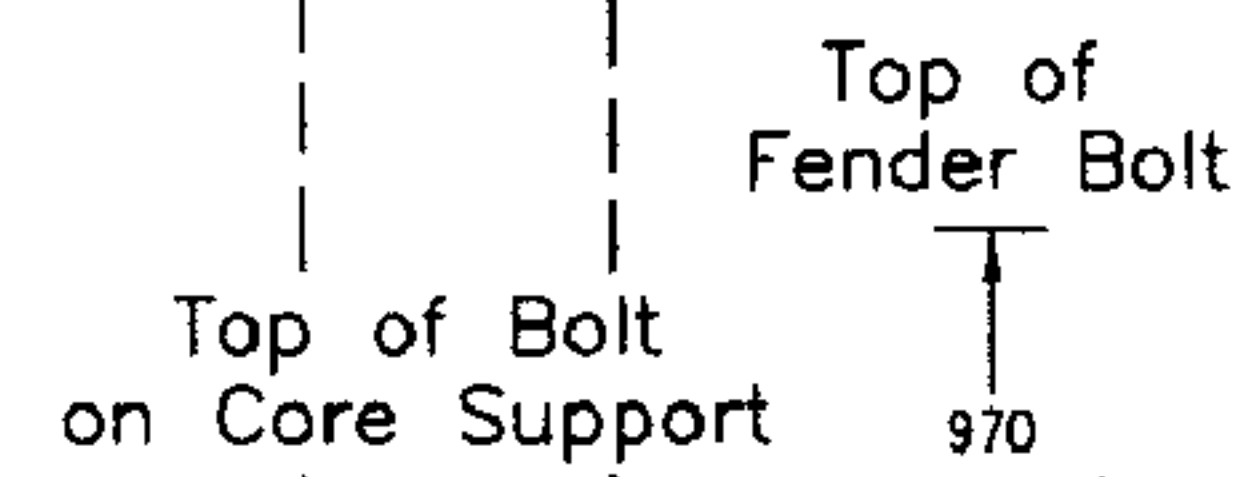
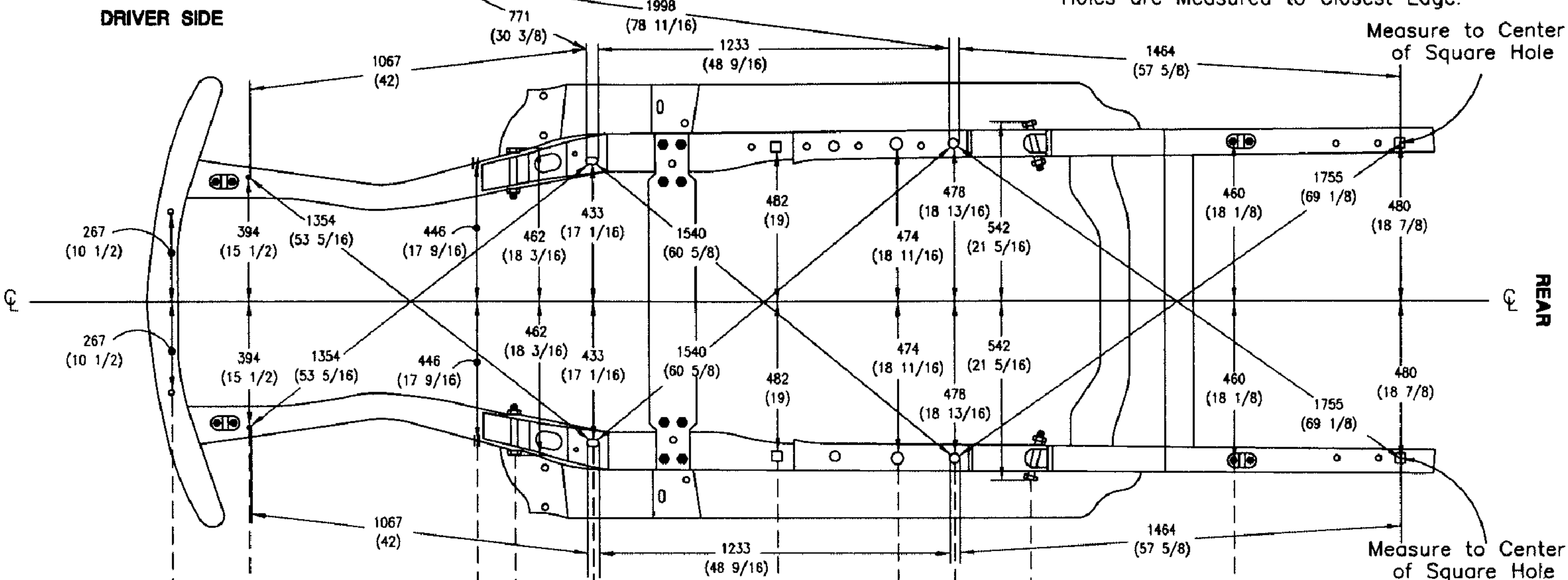

**SIDE VIEW**  
 Datum Height Dimensions are PERPENDICULAR to Datum Plane. Datum Length Dimensions are PARALLEL to Centerline of Vehicle, and are Measured Center-to-Center.

**1999-2004 WJ-Body:**  
 Fuel Filler Tube Pass-Thru Hole DELETED from Frame Section; Fill Tube Routing Revised to 'Under-Frame' Configuration

- MEASURING POINTS**
- A = 14 (9/16)
  - B = Bolt-Core Support
  - C = 8 (5/16) Threaded Hole
  - D = Fender Bolt
  - E = 12 (1/2)
  - F = Bolt
  - G = 17 x 33 (11/16 x 1 5/16)
  - H = 19 x 19 (3/4 x 3/4) Square Hole
  - I = 33 (1 5/16)
  - J = 25 (1)
  - K = Bolt
  - L = Bolt
  - M = 19 x 19 (3/4 x 3/4) Square Hole

- OVERALL DATUM LENGTHS**
- C to G = 1063 (41 7/8)
  - G to J = 1261 (49 5/8)
  - J to M = 1458 (57 3/8)

DS = Driver Side  
 PS = Passenger Side

DATUM LINE

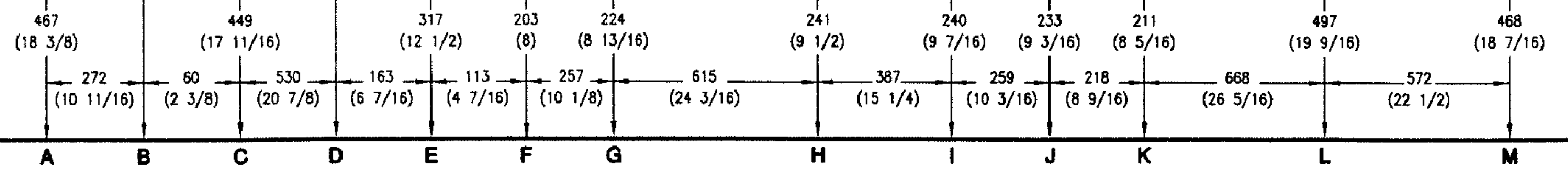

SEE PROCEDURE EXPLANATION

© 1999 MITCHELL INTERNATIONAL





PICK  
A03045L  
52100380A  
1  
PART NO.  
(0516000)  
DATE



ALL INFORMATION

DATE: 05/16/00  
TIME: 10:00 AM  
BY: [illegible]

02



# Attachment 6



OUTSIDE DESIGNED AND DEVELOPED ITEMS  
(ODD BOX ITEMS)  
ABSTRACT

This process standard establishes the business relationship between Chrysler Corporation and Suppliers of outside (supplier) design and development (ODD Box) items. An ODD Box is a part, assembly, component, or sub-system designed, developed, tooled, and produced by a supplier or jointly by a supplier

CONTENTS

<u>Topic</u>	<u>Paragraph</u>	<u>Page</u>
General	1.0	2
Organizations Identified in this Standard	2.0	2
Chrysler Approval of a Supplier	3.0	2
Design	4.0	3
Drawings/CATIA Models	5.0	3
Supplier Specifications (Standards)	6.0	4
Use of Approved Subsources	7.0	4
Safety, Regulatory, Regulated Substance, Recyclability, & Export Compliance	8.0	4
Start of Production Tooling	9.0	6
Construction and Certification of Tooling Aids	10.0	6
Control of Changes	11.0	6
Record Retention	12.0	7
Quality Assurance	13.0	7
Warranty Responsibilities	14.0	9
Serviceability and Service Parts Requirements	15.0	9
Control	16.0	10

APPENDICES

A Intellectual Property Rights, Disclosure, and Non-Confidentiality	11
B Glossary (Including Definitions)	12

A single asterisk "\*" after the paragraph header denotes a technical change to the paragraph. A triple asterisk before and after an item (\*\*\*) identifies the specific changed text.

Date	Mdl. Yr.	Eff. Code & Disp Code	PCN No.	Change	Text Changes and Cancellations
6/26/95			Editorial	J	Certain references updated
10/31/94			Editorial	H	Revised FMEA reference
Date Issued	10/25/79	Dept 2610	Contact Supv., Engr. Stds. & Info. Services		

**IMPORTANT:** Chrysler Corporation standards, specifications and drawings are subject to frequent revision. It is the users' responsibility to comply with current versions. Distribution of standards to parties other than Chrysler Corporation suppliers, whether with or without charge, is for information only. A subscription service is available at reasonable cost, which will automatically provide the subscriber with current standards. Subscription information or copies of current standards are available from the Engineering Standards & Information Services Department, Vehicle Engineering Office, Chrysler Corporation.

C References

15

Subject to Protective Order - Thomas vs. DaimlerChrysler Corporation

A single asterisk "\*" after the paragraph header denotes a technical change to the paragraph. A triple asterisk before and after an item (\*\*\*) identifies the specific changed text.

Date Cancellations	Mdl. Yr.	Eff. Code & Disp Code	PCN No.	Change	Text Changes and
6/26/95			Editorial	J	Certain references updated
10/31/94			Editorial	H	Revised FMEA reference
Date Issued	10/25/79	Dept 2610	Contact Supv., Engr. Stds. & Info. Services		

**IMPORTANT:** Chrysler Corporation standards, specifications and drawings are subject to frequent revision. It is the users' responsibility to comply with current versions. Distribution of standards to parties other than Chrysler Corporation suppliers, whether with or without charge, is for information only. A subscription service is available at reasonable cost, which will automatically provide the subscriber with current standards. Subscription information or copies of current standards are available from the Engineering Standards & Information Services Department, Vehicle Engineering Office, Chrysler Corporation.

This standard is for use in supplying certain parts under purchase orders of Chrysler Corporation or its subsidiaries. This standard is limited in its application to those drawings, CATIA Models, Engineering Graphics, or Operation Description Sheets which call out this standard number, or which refer to this standard within some other standard or specification. Original equipment and replacement parts for some vehicles sold by Chrysler Corporation or its dealers are not covered by this standard. Special Interest Vehicle Program ("Package Program") designs and modifications, done by an outside supplier, must conform to the requirements in this standard.

## 1.0 GENERAL

### 1.1 Purpose

- To define an outside designed and developed item (ODD Box Item). Refer to the Glossary at the end of this standard.
- To define and establish Chrysler Corporation and supplier responsibilities regarding parts, assemblies, components, and sub-systems furnished to Chrysler Corporation as ODD Box items.
- To recommend quote package content. Refer to the Glossary at the end of this standard.
- To assist in identifying drawings/CATIA models as supplier designed and developed.

### 1.2 Changes from the Previous Edition\*

\*\*\* Reference to the SQA manual has been superseded by reference to QS-9000. Corporate Procedure 189 has been superseded by Corporate Process Guideline 057. \*\*\*

## 2.0 ORGANIZATIONS IDENTIFIED IN THIS STANDARD

The following organizational titles refer to functional entities within Chrysler Corporation.

Assembly Plant	Procurement and Supply Office
Corporate Patent Office	Supplier Development (Quality)
Engineering (Lead Vehicle Engr. Dept)	Supplier Management (Purchasing)
Fastener Engineering	Product Development Team
Manufacturing Plant	Safety Programs
Mopar Parts Division	Supplier Quality Lab
Cataloging	Vehicle Assembly Plant
Service Parts Analysis	Vehicle Engineering Homologation Department
Tool Engineering	Vehicle/Components PF Safety Systems

## 3.0 CHRYSLER APPROVAL OF A SUPPLIER

The supplier must have full source approval, as described in Vehicle Engineering and Procurement and Supply Offices' procedures before purchase orders for design, development, or production are issued. Any deviations must be approved by Chrysler Corporation's Procurement and Supply Office. Design Verification of an ODD Box item is not a substitute for these procedures.

#### 4.0 DESIGN

Design and performance requirements are specified in the quote package, i.e. Performance Standard.

#### 4.1 Intellectual Property Rights, Disclosure, and Non-Confidentiality

Intellectual property rights, disclosure, and non-confidentiality are described in Appendix A at the end of this standard.

#### 4.2 Standard and Semi-Standard Parts

The supplier shall utilize whenever feasible Chrysler standard and semi-standard parts, purchased from approved sources. Metric fasteners shall be utilized in accordance with Chrysler's program for that vehicle family. Refer to Fastener Engineering and to the Standards Parts Book for further information.

#### 5.0 DRAWINGS/CATIA MODELS

- Detailed drawings/CATIA models are required for any component parts appearing in the Chrysler Bill of Material. Supplier must submit all drawings/CATIA models, requested in the quote package, to the Product Development Team.
- It is the responsibility of Engineering to determine the level of component detail to be carried in the Engineering Bill of Material and to subsequently manage and communicate changes to the Bill of Material by the appropriate change document.
- Detail component drawings/CATIA models intended to be released:
  - must be prepared in accordance with the Chrysler CATIA Standards Reference Manual CEP-002 and the Drawing Standards Manual CEP-004. Any deviation must be approved by the responsible engineering design, releasing, and Procurement and Supply activity.
  - must detail all interfaces with associated parts and components.
  - become the property of Chrysler Corporation.
  - must show PS-7000 and the words "ODD Box" in the standards block or comment page.
  - must list all the applicable standards in the standards block or comment page in accordance with the standards entry guidelines in Engineering Operations Bulletin 93-2. The following standards shall be listed as applicable:

Safety or Regulatory	PF-Safety PF-Noise	PF-Emissions PF-Theft Prevention
	PS-9336, "Homologation Requirements"	
Part Identification	PS-4480, "Identification of Parts"	
Quality Assurance	PS-7300, "Quality Assurance Diamonds" PS-8335, "Pentagon - Critical Verification Symbol" PS-9500, "Hydrogen Embrittlement Relief"	

Chrysler Performance Standard(s) related to the part  
Other Standards if not already referenced within the Performance Standard

- Engineering shall confirm that the list of standards in the standards block or comment page is complete and accurate and approve (sign-off) the drawing/CATIA model before its release.
- Engineering will identify critical:
  - safety/regulatory characteristics and direct the supplier to apply the shield symbol to the drawings/CATIA Models where appropriate.
  - non-safety/non-regulatory characteristics in conjunction with Procurement and Supply and direct the supplier to apply the diamond or pentagon symbols as appropriate.

Refer to the Drawing Standards, Shields-Critical Characteristics, Diamonds-Critical Characteristics, and the Pentagon-Critical Verification Symbol manuals.

**NOTE**

Supplier Development shall approve each application of "diamonds" and "pentagons" and sign-off for PS-7300 and/or PS-8335 respectively in the standards block on the drawing or comment page on the CATIA model.

- Supplemental detail information not shown on released drawings/CATIA models shall be shown on drawings/CATIA models done on supplier forms and submitted to Engineering.
- If a supplier drawing is overlaid on a Chrysler form and is no longer to scale, the drawing must be clearly marked "Do not Scale." The Chrysler Corporation title block must always be in the lower right hand corner of the drawing.
- CAD/CAM Data exchange must conform to Chrysler's Data Exchange Policy covered in PS-9227 and in Corporate Engineering Publication CEP-001.

**6.0 SUPPLIER SPECIFICATIONS (STANDARDS)**

If specified in the quote package, the supplier will submit internal specifications (standards) for the ODD Box to Engineering.

**7.0 USE OF APPROVED SUBSOURCES**

When a referenced Engineering Standard includes an Engineering Approved Source List (EASL) as an addendum, materials, processes, and components must be purchased from suppliers listed. Engineering and Procurement and Supply Offices must review any proposed deviation. The supplier is completely responsible for the quality of the end-item regardless of whether the components are purchased from an approved source or not.

**8.0 SAFETY, REGULATORY, REGULATED SUBSTANCE, RECYCLABILITY, AND EXPORT COMPLIANCE \***

Engineering shall make known the safety and regulatory requirements to the supplier and the supplier shall assure such requirements are incorporated into their products.

A. Engineering responsibilities include:

- reviewing the following documents:
  - \*\*\* Corporate Process Guideline ADM057 Vehicle Safety/Emissions/Noise/Theft Regulation Compliance. \*\*\*
  - Shields - Critical Characteristics Manual.
  - Applicable safety and regulatory standards.
  - Applicable Chrysler Compliance Procedures and MASSEs.
- clearly identifying to the supplier safety/regulatory requirements, including
  - any labelling or customer information needs.
  - certification requirements.
  - responsibility for compliance reports, documentation, etc.
- assuring that the Chrysler Performance Standard identifies specific safety and regulatory requirements.
- consulting with Safety Programs to verify that safety and regulatory requirements are being conveyed via the applicable source documents.
- consulting with the Vehicle Engineering Homologation Department to determine requirements for items and vehicles that require certification before export. Refer to PS-9336 and to Engineering Operations Bulletin 93-1.

B. The supplier must:

- consult with Engineering to assure the item meets safety and regulatory guidelines.
- submit reports and retain records as described in the \*\*\* Chrysler, Ford, and General Motors manual, Quality System Requirements QS - 9000. \*\*\*
- In conjunction with Engineering, identify critical safety and regulatory characteristics on the drawing/CATIA model. Refer to the Shields - Critical Characteristics Manual.
- identify safety, regulatory, or homologation concerns by including the appropriate Chrysler standard in the standards block on the drawing or model comment page of the CATIA model.
- meet Chrysler's requirements relative to regulated substances and recyclability. Products furnished to Chrysler Corporation or its subsidiaries and products and processes used by suppliers to manufacture those products must conform to the requirements in CS-9003.
- date code shielded parts, refer to PS-4480.
- mark plastic parts with the plastic Standard Marking Symbol as described in PS-4480.

All changes must meet the requirements in paragraph 11.0.

## 9.0 START OF PRODUCTION TOOLING

Upon concurrence of the Product Development Team that tooling may begin, Supplier Management will notify the supplier. The supplier is not to begin actual tooling until authorized by the Supplier Management representative either by:

- a Tooling Purchase Order
- direct communication, such as an "OK TO TOOL AUTHORIZATION NOTICE."

Refer to the "OK to Tool" Authorization Notice Operating Process booklet.

## 10.0 CONSTRUCTION AND CERTIFICATION OF TOOLING AIDS

Tooling aid(s) requirements should be specified in the quote package. Suppliers or their agents are to certify the accuracy of the specified tooling aid(s).

## 11.0 CONTROL OF CHANGES

### 11.1 Authorization

Changes affecting parts, designs, standards, materials, processes, subsources, or program requirements including performance, assembly, quality, timing, durability, warranty, service, compliance with governmental regulations, or customer satisfaction must be authorized by Chrysler.

- A. **No change shall be made by the supplier without prior approval by Chrysler.**
- B. Supplier may request a change to a part by submitting either a completed:
  - "Supplier Request for Product Change" (SRPC). Refer to the Glossary.
  - "Chrysler Change to Supplier 'Odd Box' Item" (formerly known as the "Black Box Form")
- C. Any change to the end item made after award of business:
  1. must be authorized and documented on the appropriate Chrysler change document. Refer to the Glossary.
  2. requires Engineering to forward a copy of the change document along with appropriate supporting documentation to Procurement and Supply.
- D. Suppliers will be required to respond promptly to a change document with cost, timing, and weight impact as requested. Chrysler Corporation will not be responsible for additional cost of supplier-initiated changes unless approved by Chrysler Engineering and Supplier Management, prior to the supplier making the change. The Product Development Team shall review the cost impact of the proposed changes. Disagreements regarding costs are to be resolved by the Supplier Management representative.

### 11.2 Drawings/CATIA Models

As each change occurs, the supplier must:

- submit updated drawings/CATIA models to Engineering.
- show the authorizing change document in the change block or CATIA model comment page.

If the change is 35 weeks prior to launch or later, the supplier must also notify Service Parts Analysis. Changes to released drawings must follow Chrysler drawing practices.

**NOTE**

Changes to supplier drawings/CATIA models or supplier specifications (standards) must follow either Chrysler or ANSI practices.

**11.3 Supplier Specifications (Standards)**

If an authorized change affects the supplier's internal specifications (standards), the supplier must submit copies of the revised document to Engineering; and if the change is 35 weeks prior to launch or later, the supplier must also notify Service Parts Analysis.

**11.4 Changes of Second Tier Sources**

The primary supplier, using the form "Chrysler Change to Supplier 'Odd Box' Item", shall notify Engineering, Procurement and Supply, and Service Parts Analysis when a change of subresources is being contemplated, whether or not the source is included on an Engineering Approved Source List.

**11.5 Safety, Regulatory, Regulated Substances, Recyclability, and Export Compliance**

Any running change to the design after compliance validation, must be evaluated for compliance implications. If compliance with a government regulation is affected, re-certification will be required:

- for safety and/or regulatory concerns, Engineering must notify Safety Programs. In addition, a supplemental compliance report may be required.
- for export approval, Engineering must notify the Vehicle Engineering Homologation Department to arrange for export re-certification; refer to PS-9336.
- for approval of restricted or regulated substances, the supplier must submit a revised "Supplier Regulated Substance and Recyclability Certification Report;" refer to CS-9003.
- to report changes in recyclability, the supplier must submit a revised "Supplier Regulated Substance and Recyclability Certification Report;" refer to CS-9003.

**11.6 Production Part Approval**

Refer to paragraph 13.3.

**12.0 RECORD RETENTION \***

Engineering shall maintain drawings/CATIA models and supplier specifications including all changes per the requirements in Engineering Operations Bulletins 92-1, "Record Retention Requirements" and in \*\*\* "Corporate Procedure ADM 062, "Records Management." \*\*\*

**13.0 QUALITY ASSURANCE**

**13.1 Design Verification**

As depicted in the Chrysler Performance Standard or quote package, suppliers shall furnish sample pre-production parts along with a completed "Pre-production Sample Report" to Engineering.



### 13.2 Production Validation

The supplier shall conduct Production Validation as specified in the applicable Performance Standard.

#### NOTES

Design Verification and Production Validation must be completed prior to the Process Signoff and the Production Part Approval Process Warrant submission. Successful completion of Design Verification and Production Validation does not fulfill production quality control requirements.

Any Changes (including changes to subsources, materials, processes, etc.) may require repeating Design Verification and/or Production Validation at the discretion of Engineering or Supplier Development.

### 13.3 Production Part Approval Process (PPAP)

Production Part Approval Process describes production part review and approval prior to the first quantity shipment to a Chrysler plant. The Production Part Approval Process determines if all the engineering requirements are properly understood and if the process has the potential to produce parts meeting requirements. PPAP must be successfully completed before a supplier ships the first quantity shipment to a Chrysler facility. Refer to the Glossary for further information.

Supplier submission requirements to the respective Chrysler facilities for PPAP are shown below:

- Vehicle Assembly Plants

Self-certified suppliers of end-items to Chrysler vehicle assembly plants must submit a Warrant to Chrysler's Supplier Quality LAB. Suppliers who are not classified as self-certified must submit their parts to an independent laboratory approved by Chrysler for tests and dimensional inspections, prior to submitting their Warrant to the Supplier Quality Lab.

- Chrysler Manufacturing Plants (Powertrain, Acustar, etc)

Self-certified suppliers of end-items to Chrysler plants other than assembly plants must submit a Warrant to the respective Chrysler manufacturing plant. Suppliers who are not classified as self-certified must submit along with the Warrant, sample parts and test and dimension inspection results to the Chrysler manufacturing plant.

When materials, subsources, processes, specifications, etc. for parts are changed, the supplier must repeat the production part approval process unless Engineering has waived this requirement for this specific change. Refer to AIAG's Production Part Approval Process manual and to paragraph 11.0.

For further instructions contact the responsible Supplier Management representative.

### 13.4 Continuing Conformance Requirements

Upon satisfactory completion of the requirements in paragraphs 13.1 through 13.3, the supplier must conduct Continuing Conformance Inspection/Tests as defined in the applicable Performance Standard. Shipments of parts for production and for Mopar Parts Division must conform to all specified requirements.

### 13.5 Supplier's Quality System Requirements

Suppliers must have a quality system plan to assure that only defect free parts are shipped to Chrysler. Suppliers must adhere to the current Chrysler quality system requirements.

## 14.0 WARRANTY RESPONSIBILITIES

### 14.1 Production Items and Systems

Warranty cost reduction/elimination is the joint responsibility of Chrysler Corporation and the supplier. Chrysler Corporation has overall system responsibility to ensure that the system operation does not cause a supplier component failure. The supplier has total responsibility for the quality and reliability of the components supplied and will be held accountable for any system failures attributable to failure of the supplier's components. Such responsibility will include:

- reimbursement of Chrysler's total actual costs in extending a warranty on the supplied component, including but not limited to Chrysler's total reimbursement to its dealers for parts and labor.
- defending and indemnifying Chrysler Corporation against all claims, liabilities, losses, consequential and other damages, and settlement expenses for injury or death of any person and damage or loss of any property allegedly or actually resulting from failure of the supplier's components.

### 14.2 Service Items

Supplier has responsibility for Service Part Warranty. This warranty will cover failures of supplied components sold by Chrysler dealers to customers outside of the new vehicle warranty.

## 15.0 SERVICEABILITY AND SERVICE PARTS REQUIREMENTS

Service information is the joint responsibility of Chrysler Corporation and the supplier. Decisions regarding how to provide service parts are the responsibility of the Supplier, Engineering, and Service Parts Analysis.

The supplier in conjunction with Engineering must design production parts, kits, and service assemblies that:

- incorporate serviceability design objectives.
- meet MOPAR parts supply needs and design objectives.
- require the minimum of special tools.
- consider low volume service production requirements.

Suppliers must provide:

- serviceability information.
- Mopar Parts, including Cataloging, Service Parts Analysis, and Tool Engineering with drawings/CATIA models, material and process specifications, graphic illustrations, or actual sample part assemblies.
- Service Parts (MOPAR) Purchasing and Service Parts Analysis approximately 35 weeks before volume production with a priced bill of material, in a structured format indicating recommended serviceable parts. The bill of material should also identify second and third tier sources.

- assurance (guarantee) that service assemblies and components are available for the entire service retention period.

Changes affecting service parts shall be handled according to the instructions in paragraph 11.0, as appropriate.

#### 16.0 CONTROL

This standard was issued by Chrysler's Engineering Standards and Information Services Department. All proposed changes should be directed to them for approval, prior to implementation.

This standard was revised through the efforts of a task force, consisting of representatives from Supplier Development, Supplier Management, Engineering Standards and Information Services, Small Car Engineering, Large Car Engineering, and MOPAR Parts Division.

#####

**APPENDIX A: INTELLECTUAL PROPERTY RIGHTS, DISCLOSURE, AND NON-CONFIDENTIALITY**

**INTELLECTUAL PROPERTY RIGHTS**

Ownership of intellectual property, such as trade secrets, patents, trade marks, and copyrights, is addressed in the purchase order through rider clauses 98, 98A, and/or 99. Copies of these clauses are available from Supplier Management.

**DISCLOSURE**

Supplier at the time of preliminary discussions shall provide Engineering and Supplier Management total disclosure of supplier's patents and patent applications relating to the item to be provided by the supplier.

**NON-CONFIDENTIALITY**

It is Chrysler's policy not to enter into formal confidentiality agreements with its suppliers or potential suppliers.

Information, such as material, literature, specifications, blue-prints, CATIA models, samples, or data relating to a particular ODD Box item provided by a supplier shall not bear written "Restricted," "Confidential," or "Proprietary" notations or markings pertaining to confidential requirements or other restrictions limiting usage of the data itself or parts or processes to which it relates. Suppliers shall be asked to delete and initial any such notations, markings, or restrictions. In any event, any such notations, markings, or restrictions shall not prevent Chrysler personnel from using such information or from disclosing such information to others who have a need to know such information.

To foster the exchange of proprietary information or confidential information, Chrysler and the supplier shall rely on each other's ethics to handle each other's proprietary or confidential information in the same manner as each handles its own proprietary or confidential information. Further, the exchange of such information is with the understanding that disclosure of such information from one party to the other neither constitutes a public divulgence nor creates a bar to filing patent applications anywhere in the world.

APPENDIX B: GLOSSARY \*

**AIAG.** AIAG (Automotive Industry Action Group) is a trade association formed to increase productivity and competitiveness through a cooperative effort between manufacturers and suppliers.

**CATIA.** CATIA is the acronym for Computer Aided Three-Dimensional Interactive Application software which is used to create computer aided design models.

**Change Document.** Within this document, the term "change document" refers to the appropriate change instrument: Product Change Notice (PCN), Advance Product Change Notice (APCN), Change Notice (CN), Material Change Notice (MCN), Chrysler Change to an ODD Box form, SRPC, etc.

**AMCN.** AMCN stands for an Advance (pre-release) Material Change Notice.

**APCN.** An APCN (Advance Product Change Notice) communicates and coordinates part design and change information prior to release of the production drawing.

**CN.** A CN (Change Notice) is a streamlined version of a Product Change Notice (PCN); it automatically includes an MCN.

**MCN.** After release, an MCN (Material Change Notice) is the supplier's official authorization from Chrysler to implement a change in response to a product change notice (PCN). It associates costs with a PCN. (A CN encompasses an MCN and is not a separate process.)

**(ODD Box form) Chrysler Change to a Supplier 'Odd Box' Item.** Formerly known as a "Black Box Form" is used to request and approve changes to a drawing/CATIA model, Engineering Standard, process, material, or subsource. This form (NPM # 84-806-1609), included in the General Terms and Conditions, can be obtained from the responsible Supplier Management representative. If the change affects appearance, performance, quality, or costs, a change document may be required.

**PCN.** A PCN (Product Change Notice) documents, describes, and communicates a product change.

**(SRPC) Supplier Request for Product Change.** An SRPC (NPM # 84-806-1849) is a Chrysler form used by the supplier to obtain approval for **no-cost changes which do not affect performance, assembly, quality, durability, warranty, or customer satisfaction**. SRPCs are used for changes that will be visible on a drawing/CATIA Model. Refer to Engineering Operations Bulletin 85-5.

**Design Aids.** Design aids are used in developing and proving out fit, finish, and clearance among mating parts and in determining conformance to assembly, serviceability, installation, and appearance specifications.

**Engineering.** Within the context of this standard, the term "Engineering" denotes the lead Chrysler Vehicle Engineering design department.

**Engineering Approved Source List (EASL).** An Engineering Approved Source List is a list of suppliers approved by Engineering and the Procurement and Supply Office. An EASL is included as an addendum to an Engineering Standard. Refer to the Engineering Standards Writers' Guide.

ISIR/ISLR (Initial Sample Inspection Report/Initial Sample Laboratory Report). This term has been superseded by the "production part approval process." Refer to paragraph 13.3.

Outside Design and Development Item ("ODD Box"). A part, assembly, component, or vehicle sub-system designed, developed, tooled, and produced by a supplier or jointly by a supplier and Chrysler. An ODD Box may fit any of the following categories:

1. A proprietary item to which the supplier retains ownership of the intellectual property rights.
2. An adaption of the paragraph above. Modification may be made to meet Chrysler Corporation performance, identification, or packaging requirements, but the supplier retains all the intellectual property rights to the item.
3. An item designed and developed from Chrysler Corporation concepts to meet a specific need. Supplier designs and develops the item, but Chrysler Corporation owns all the intellectual property rights to the item.
4. A combination of the above items.

Pre-Production Sample Report. \* Part suppliers are required to submit a Pre-production Sample Report on pre-production parts during the program/pilot phases, prior to Production Part Approval Process Warrant submission.

Production Parts and Production Samples. Production Parts are manufactured at the production site using production tooling, gaging, processes, materials, operators, environment, and process settings, e.g. production feeds/speeds/cycle times/pressures/temperatures. Production Samples are production parts taken from a significant production run. Refer to AIAG's Production Part Approval Process manual.

Production Part Approval Process (PPAP). Production Part Approval Process is a process adopted by Chrysler, Ford, and General Motors to simplify and standardize customer (Chrysler) approval of initial samples; at Chrysler it replaces ISIR/ISLR sample submission requirements. Refer to AIAG's Production Part Approval Process Manual.

Quote Package. A collection of information which defines and explains Chrysler Corporation and supplier responsibilities and requirements. It includes information to enable the suppliers to fulfill their responsibilities and requirements. The following list depicts typical topics for a quote package and is not intended to be all inclusive:

certification requirements

- production part approval process
- Supplier Regulated Substance and Recyclability Certification Report
- tooling aids

CATIA design and transmission capabilities, in-house

documentation requirements

- drawings or CATIA models meeting Chrysler Corporation Engineering Standards
- pictorials or graphics
- supplier prints

supplier specifications (standards)

interface drawings/CATIA models

Design Verification Plan and Report (DVP & R)

FMEAs-design and process (SAE J1739, "Potential Failure Mode and Effects Analysis ....")

management approval, i.e., executive engineer's letter

milestone chart (time line)

- advanced quality plan
- applicable master timing schedule dates
- process sign-off date (process sheets, inspection instructions, gages, initial samples, and packaging)
- priority parts quality review (PPQR) dates

part name, number, and description - Chrysler (end-item)

Process Standard, PS-7000

Performance Standard for the item (including expected quality/reliability)

prototype requirements

purchase order rider clauses 98, 98A, and 99 as appropriate

recyclability requirements

sales code(s)

sample requirements (design verification, production validation, production part approval process)

standards, other applicable (Material, Process, Characteristic, etc.)

subsources (subsuppliers) if deemed necessary

serviceability and service parts requirements, refer to paragraph 15.0

target investment

target piece price

target weight

tooling aids

tooling capacity

volumes planned for each production year

Questions concerning the content of the quote package should be directed to the Supplier Management representative.

Released Drawings/CATIA models. Drawings approved by Chrysler design, Engineering, engineering management, and engineering release activities for production or special interest vehicle programs.

Special Interest Vehicle Program ("Package Program"). A program to provide special limited-volume sales models or options by modifying production vehicles prior to shipment to dealers.

Standard Parts. Parts for which specifications are published in the Standard Parts book.

Semi-Standard Parts. Parts which differ enough from Standard Parts to require their own separate drawing/CATIA model.

Supplier. The term supplier refers to both Corporate and outside sources.

**APPENDIX C. REFERENCES\***

The documents, standards, and forms referenced within this standard are listed below and are available from the organizations depicted below:

**SOURCES OF REFERENCES FOR CHRYSLER TEAM MEMBERS**

\*\*\* Corporate Process Guidelines (CPGs) (Available on HPCICS2 on Chrysler's Information Systems)

ADM057 Vehicle Safety/Emissions/Noise/Theft Regulation Compliance  
ADM062 Records Management \*\*\*

Engineering Standards and Information Services Department

Compliance Procedures <sup>1</sup>  
Diamonds-Critical Characteristics and the Pentagon-Critical Verification Symbol manuals  
Engineering Operations Bulletins:<sup>1</sup>  
85-5 "Supplier Request for Product Change (SRPC) Procedure"  
92-1 "Record Retention Requirements"  
93-1 "Homologation Requirements"  
93-2 "Entering Engineering Standard Numbers on Drawings and EBOM"  
Engineering Standards, Standards Parts book  
Engineering Standards Writers' Guide  
Engineering Standards (MS, PS, PF, CS, and AS) <sup>1</sup>  
PS-4480 "Identification of Parts"  
PS-7300 Quality Assurance Diamonds  
PS-8335 Pentagon-Critical Verification Symbol  
CS-9003 "Environmental, Health, and Occupational Safety ....  
PS-9227 "CAD/CAM Data Exchange Policy"  
PS-9336 "Homologation Requirements"  
PS-9500 "Hydrogen Embrittlement Relief"  
Chrysler safety standards, e.g. PF-SAFETY <sup>1</sup>  
Motor Vehicle Safety Standards <sup>1</sup>  
CEP-001 CAD/CAM Data Exchange Policy <sup>1</sup>  
CEP-002 Catia Standards Reference Manual <sup>1</sup>  
CEP-004 Drawing Standards Manual<sup>1</sup>  
Shields Critical Characteristics manual

Product Strategy and Regulatory Affairs Office, Vehicle Compliance and Safety Affairs Dept.  
Vehicle Components PF Safety Systems

Applicable MASSEs (Manufacturing Assurance Standard Safety/Emissions)

Safety Programs

Compliance Procedures, Reports, & Supplemental Compliance Reports  
Motor Vehicle Safety Standards and regulations

Supplier Management Organization of Procurement and Supply

Procurement and Supply Procedures ....  
Purchase Order Rider Clauses 98, 98A, and 99



Vehicle Engineering Platforms Program Management Team

"OK to Tool" Authorization Notice Operating Process

**SOURCES OF REFERENCES FOR SUPPLIERS**

Automotive Industry Action Group (AIAG)\*

\*\*\*Chrysler, Ford, and General Motors manual, Quality System Requirements QS - 9000 \*\*\*  
Production Part Approval Process

Customer Satisfaction & Vehicle Quality, Chrysler Quality Institute

Diamonds-Critical Characteristics and the Pentagon-Critical Verification Symbol manuals  
Shields Critical Characteristics manual

Engineering Standards and Information Services

CEP-001 CAD/CAM Data Exchange Policy  
CEP-002 Catia Standards Reference Manual

\*\*\* Integrated Systems Development, Holland Michigan 49422 (Phone 616-396-0880) \*\*\*

Characteristic, Material, Performance, and Process Standards  
CEP-004 Drawing Standards Manual  
Engineering Standards, Standards Parts book

Society of Automotive Engineers (SAE)

J1739, "Potential Failure Mode and Effects Analysis...."

Supplier Management Organization of Procurement and Supply

Chrysler Change to Supplier "Odd Box" Item (NPM # 84-806-1609)  
Purchase Order Rider Clauses 98, 98A, and 99  
Supplier Request for Product Change - SRPC (NPM # 84-806-1849)

---

1. Available on-line on the Automated Document Retrieval and Engineering Standards System (ADDRESS®).

**End of Strickland Document**